

# **ROKR<sup>®</sup>** **LOKOMOTYWA**

LK701-v2

DREWNIANE PUZZLE 3D

MODELE MECHANICZNE

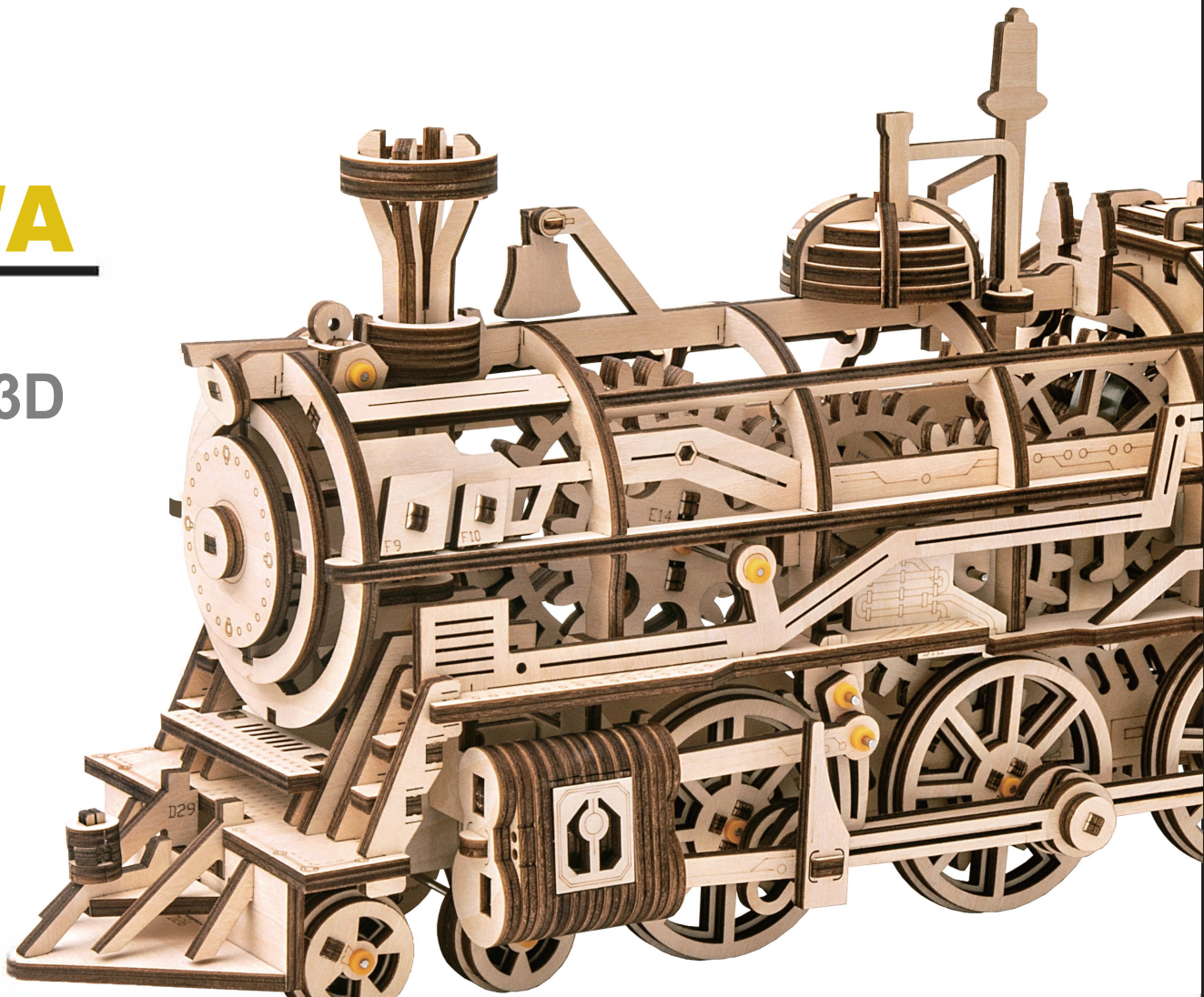

**INSTRUKCJA ZŁOŻENIA**

## OSTRZEŻENIE

Zestaw zawiera małe elementy-ryzyko zadławienia.  
Produkt przeznaczony dla osób powyżej **14 lat**.  
Dzieci muszą składać pod nadzorem dorosłych.

## KONSERWACJA

- 1.Trzymaj produkt daleko od źródeł ognia.Nie zanurzaj w wodzie.
- 2.Nie używaj środków do czyszczenia zawierających alkohol lub amoniak.
- 3.Użyj czystej,miękkiej tkaniny aby wyczyścić produkt.



ZESKANUJ KOD QR

## UWAGA

- Oddziel elementy od ramy zgodnie z każdym krokiem instrukcji przed montażem i umieść je prawidłowo.
- Pewne elementy mają numery.Dopasuj numery podczas montażu.
- Dodatkowe elementy można wykorzystać jako części zamienne.
- W razie potrzeby wyszlifuj elementy papierem ściernym.
- W przypadku problemu z montażem zeskanuj kod QR,aby zobaczyć film instruktażowy.
- Proszę zachować instrukcję,gdyż zawiera ważne informacje.

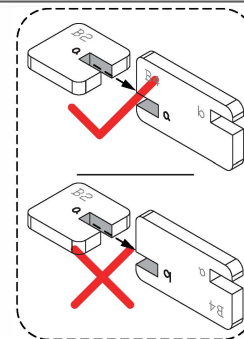

Podziel się z nami swoją opinią na temat produktu lub zaprezentuj swój model na :

**facebook.com/robotimepolska**

Sprawdź również zawsze aktualną ofertę oraz nasze nowości na :

**www.robotime.com.pl**

Chętnie odpowiemy na wszystkie pytania.

PROBLEM	PRZYCZYNA	ROZWIĄZANIE
Model nie porusza się po nakręceniu.	<ol style="list-style-type: none"><li>1.Dźwignia hamulca pozostaje opuszczona.</li><li>2.Tarcie pomiędzy kołem zębatym a elementem podtrzymującym (długi element używany do mocowania przekładni) jest nadmierne.</li><li>3.Tarcie między korbowodem na zewnątrz koła zębatego jest nadmierne. Lub tarcie między korbowodem a silnikiem jest nadmierne.</li><li>4.Odstęp między zębatkami jest nadmierny.</li></ol>	<ol style="list-style-type: none"><li>1.Przesuń dźwignię hamulca do góry.</li><li>2.Obróć koło zębate i upewnij się, że jest wystarczająca przestrzeń między przekładnią a elementem wspierającym.</li><li>3.Obróć przekładnię i sprawdź, czy korbowody mogą pracować płynnie.</li><li>4.Nieznacznie wyreguluj położenie kół zębatach.</li></ol>

 Zamontuj części symetrycznie.

 Wyszlifuj części papierem ściernym.

 Upewnij się, że części obracają się swobodnie.

 Zwróć uwagę podczas montażu.

 Upewnij się, że części są odpowiednio dopasowane.

 x2 Wykonaj 2 sztuki.

 Użyj noża aby przeciąć części.









 Potrzebny wosk lub smar.



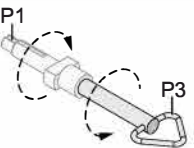





 Zmiana perspektywy. Obróć zgodnie z kierunkiem strzałki na zdjęciu.

 1 Krok 1  2 Krok 2

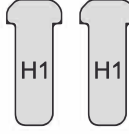
 3 Zmontuj krok 3 zgodnie z krokiem 1.

## Lista elementów

Element	Aksesoria sprężyny	Sprężyna	Klucz	Wosk	Rękaw drążka	Stalowy drążek	Stalowy drążek	Stalowy drążek	Stalowy drążek
Numer	P1	P2	P3	P4	P5	P6	P7	P8	P9
Ilustracja									
Ilość	1	1	1	1	60	7	2	1	1

Element	Stalowy drążek	Stalowy drążek	Kołek	Kołek				Kołek	Kołek
Numer	P10	P11	H1	H2				H3	H4
Ilustracja									
Ilość	7	1	2	4				2	2

**Rady:**

 Jeśli po złożeniu połączenie nie jest wystarczająco mocne użyj kleju.

 Dopchnij elementy do końca.

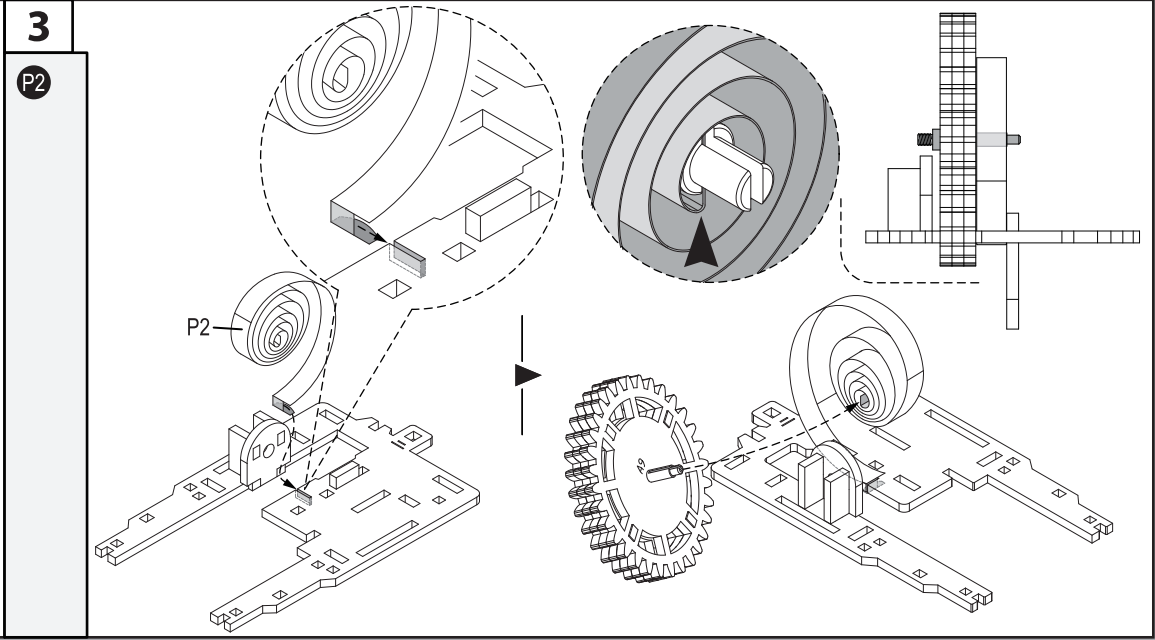
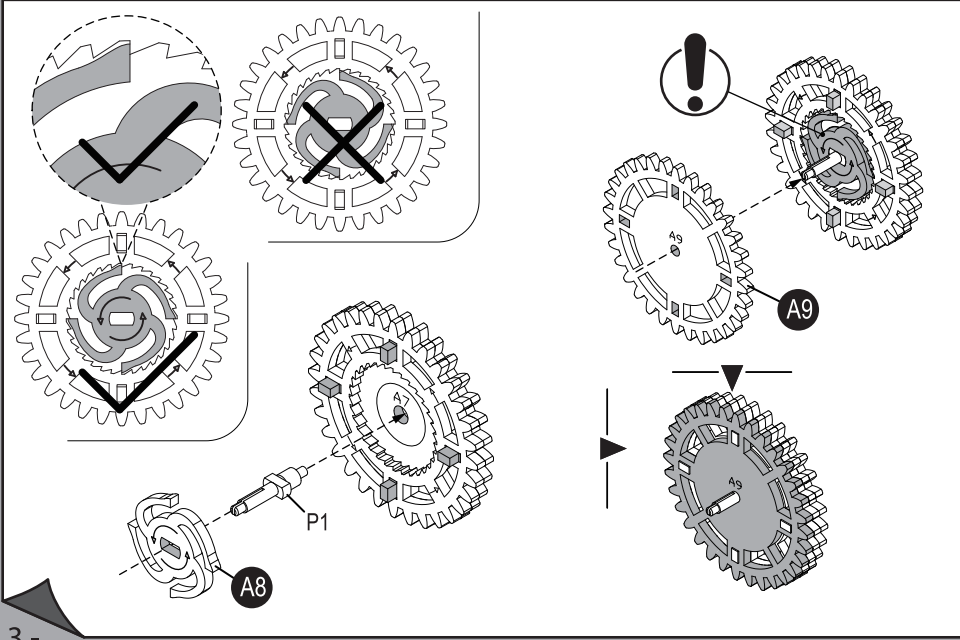
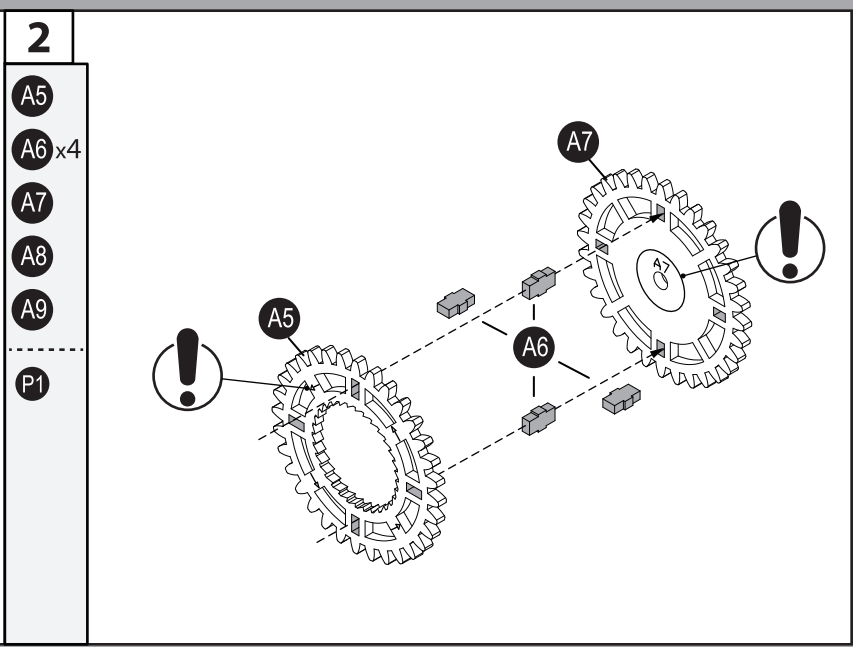
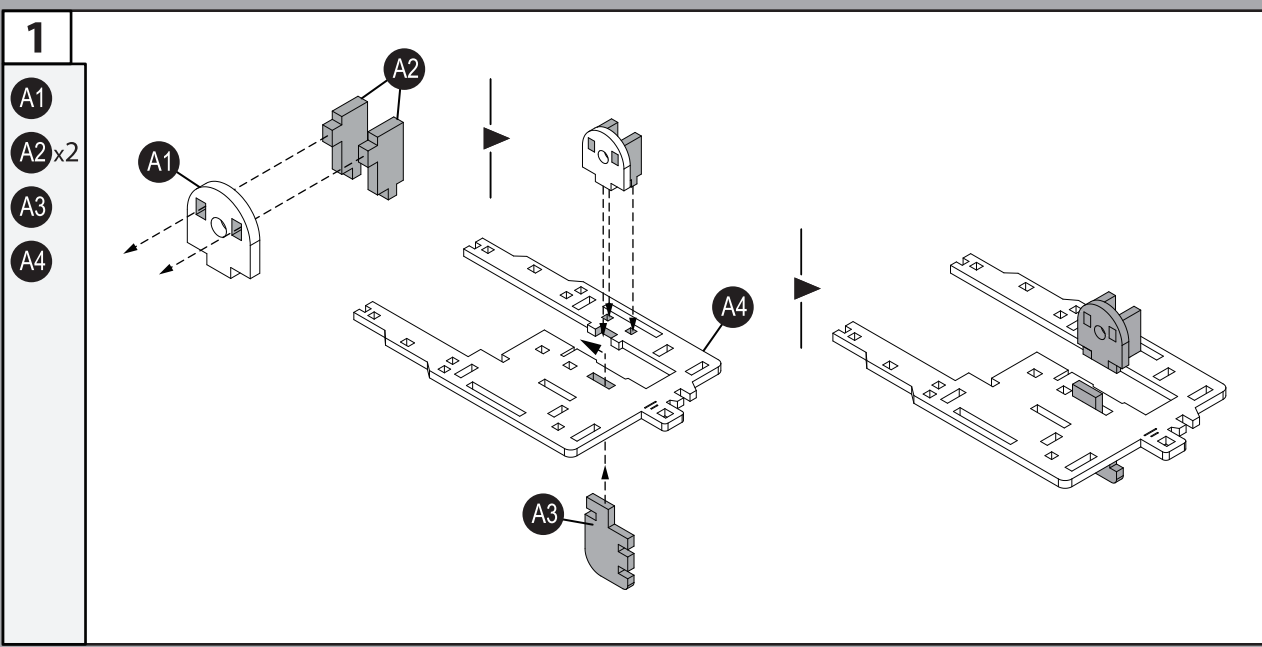

4

- A10
- A11
- A17

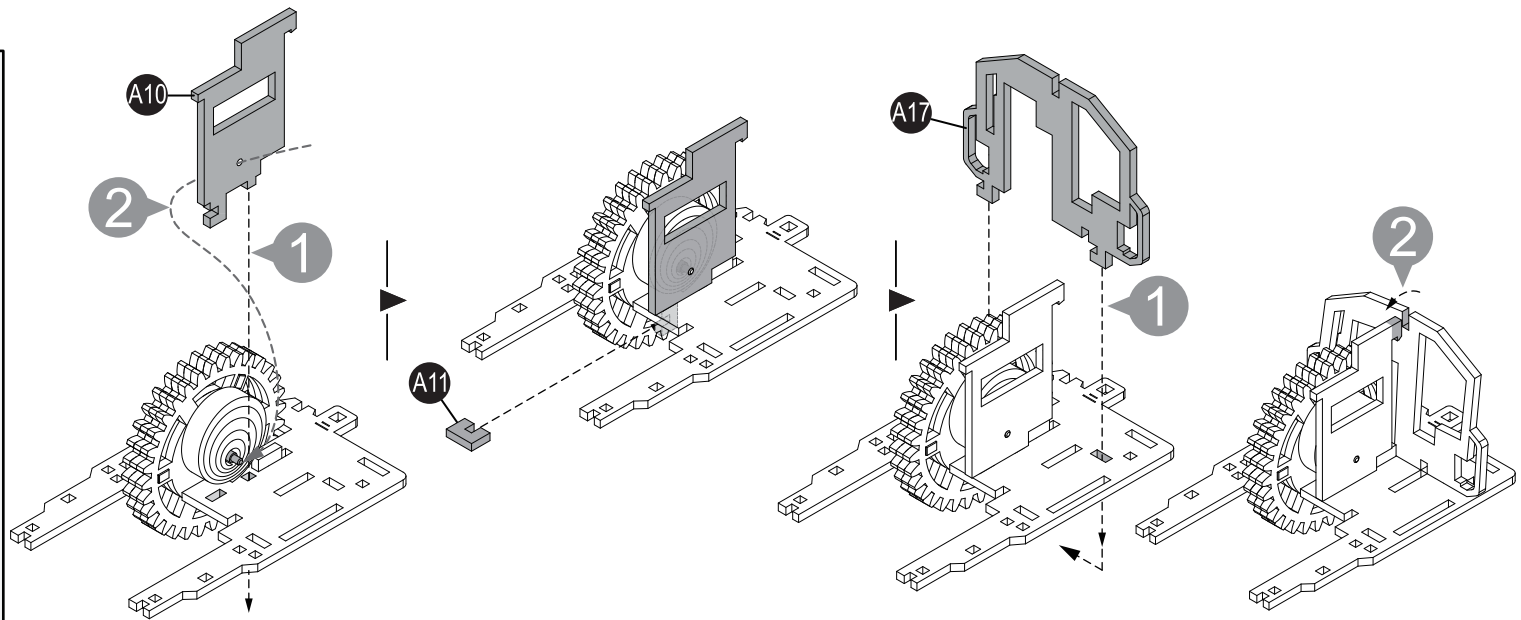
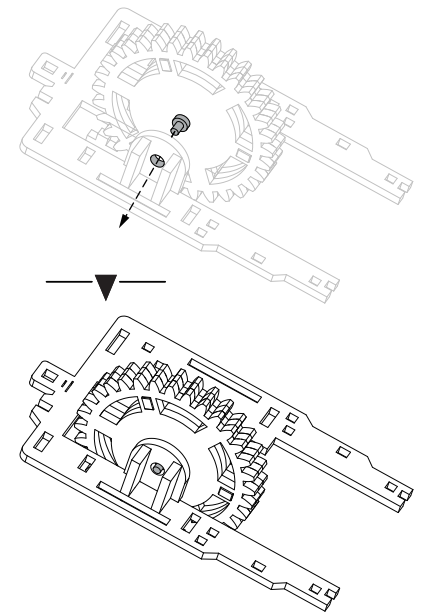

- A12
- A13
- A14x4
- A15
- A16
- A18

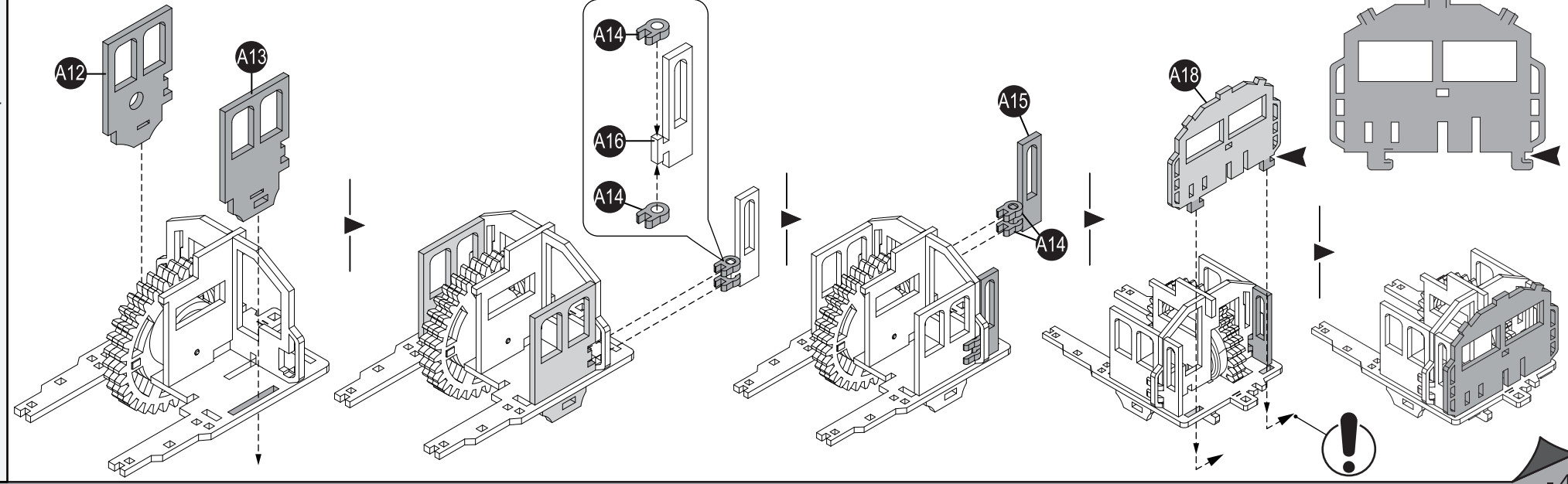

**5**

- B1**
- B2**
- B3**
- B4**

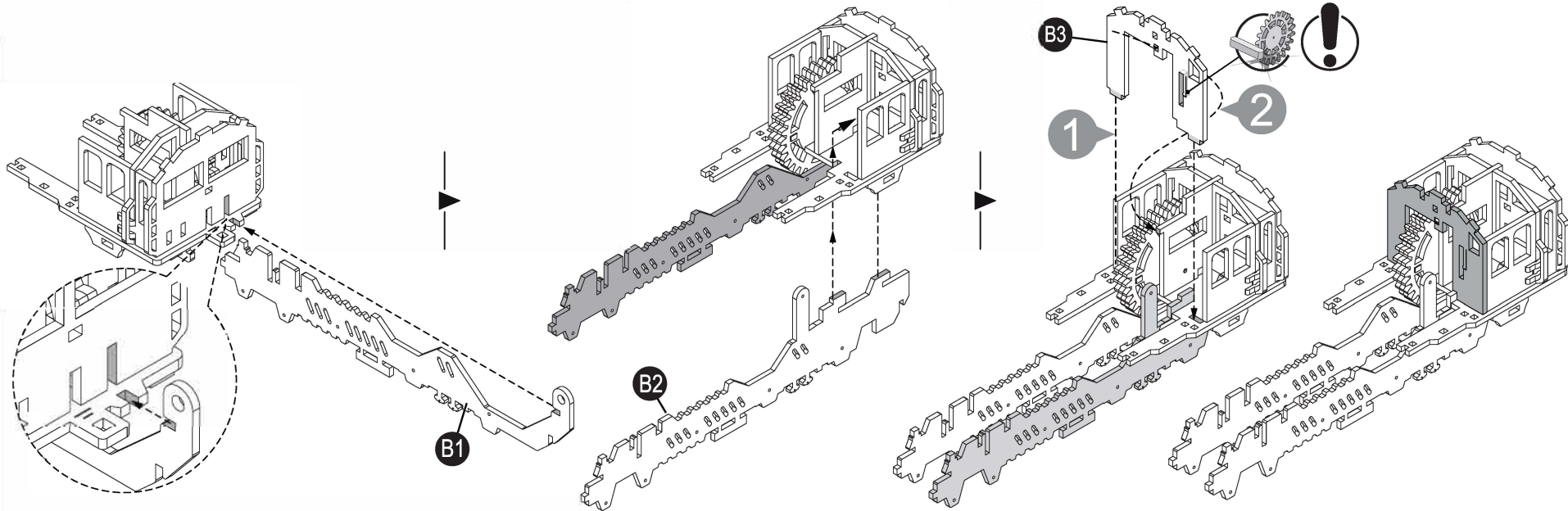
**6**

- C1** x2
- C2** x8
- C3** x2
- C4** x2

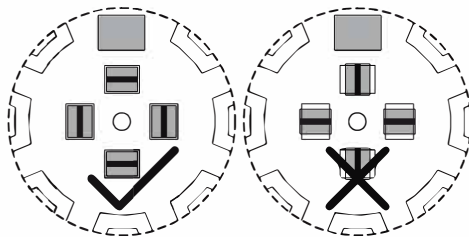

Zeskanuj kod QR aby zobaczyć film instruktażowy.

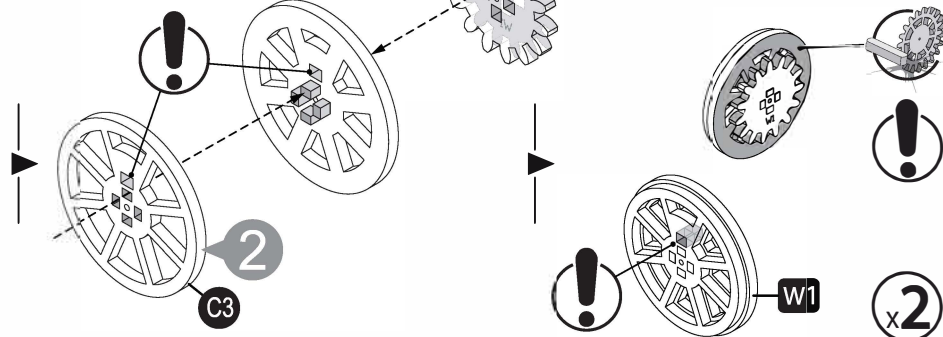
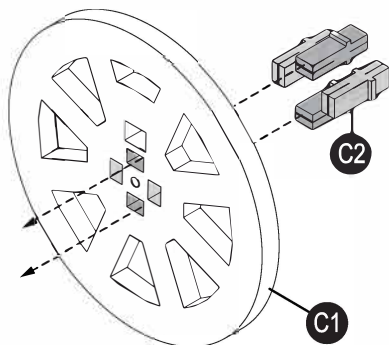
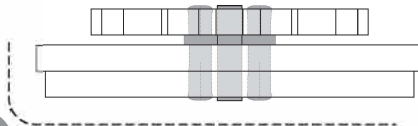

**7**

**C1** x3  
**C2** x12  
**C3** x3  
**C5** x3

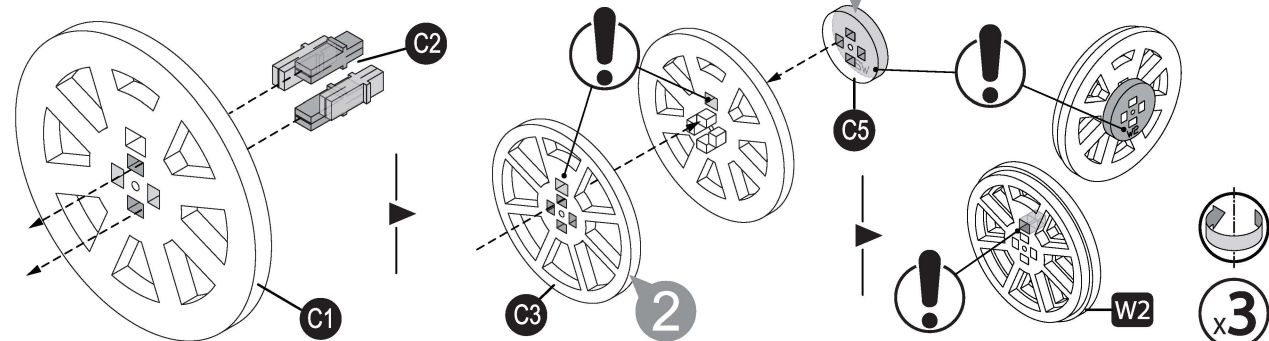
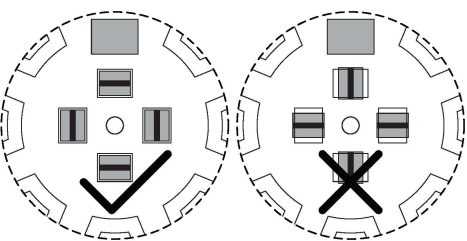
**8**

**C1**  
**C3**  
**C6** x4

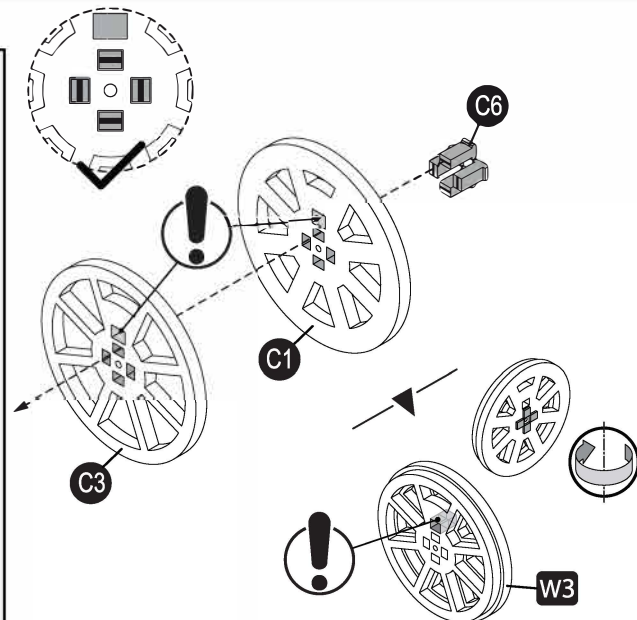
**9**

**C7** x4  
**C8** x8  
**C9** x4

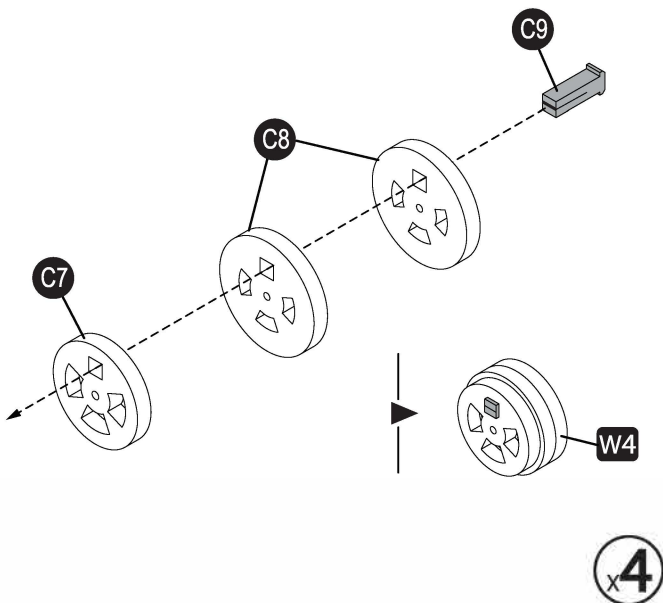
**10**

**C10** x2  
**C11**  
**C12**  
**G22**  
**P5** x2  
**P10**

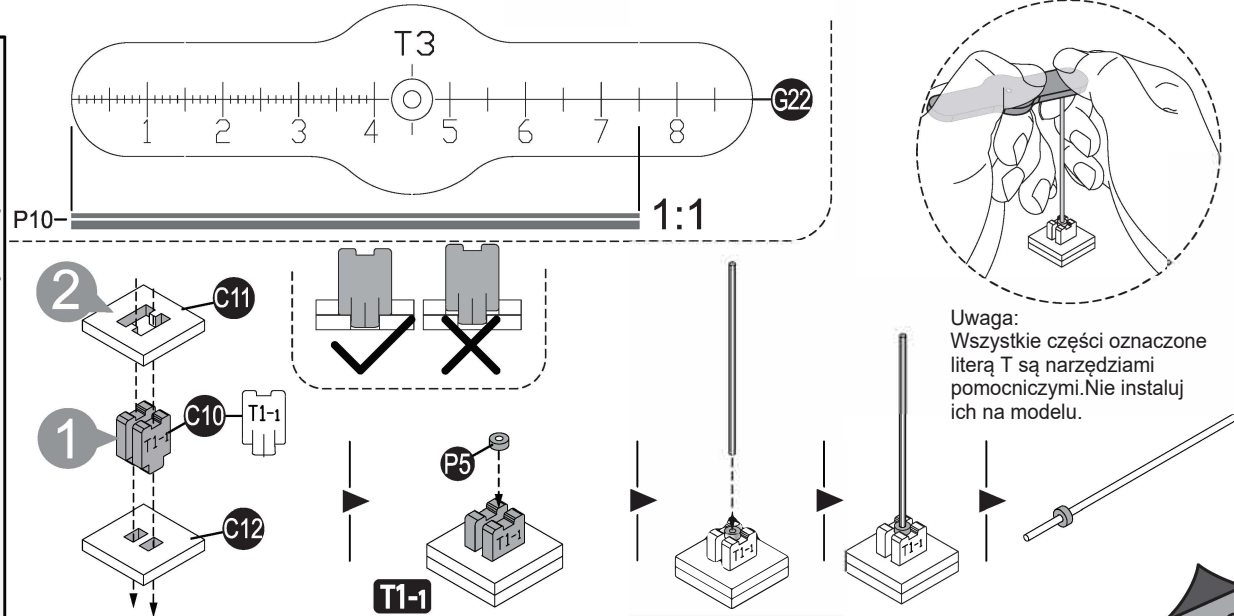

Uwaga:  
 Wszystkie części oznaczone literą T są narzędziami pomocniczymi. Nie instaluj ich na modelu.

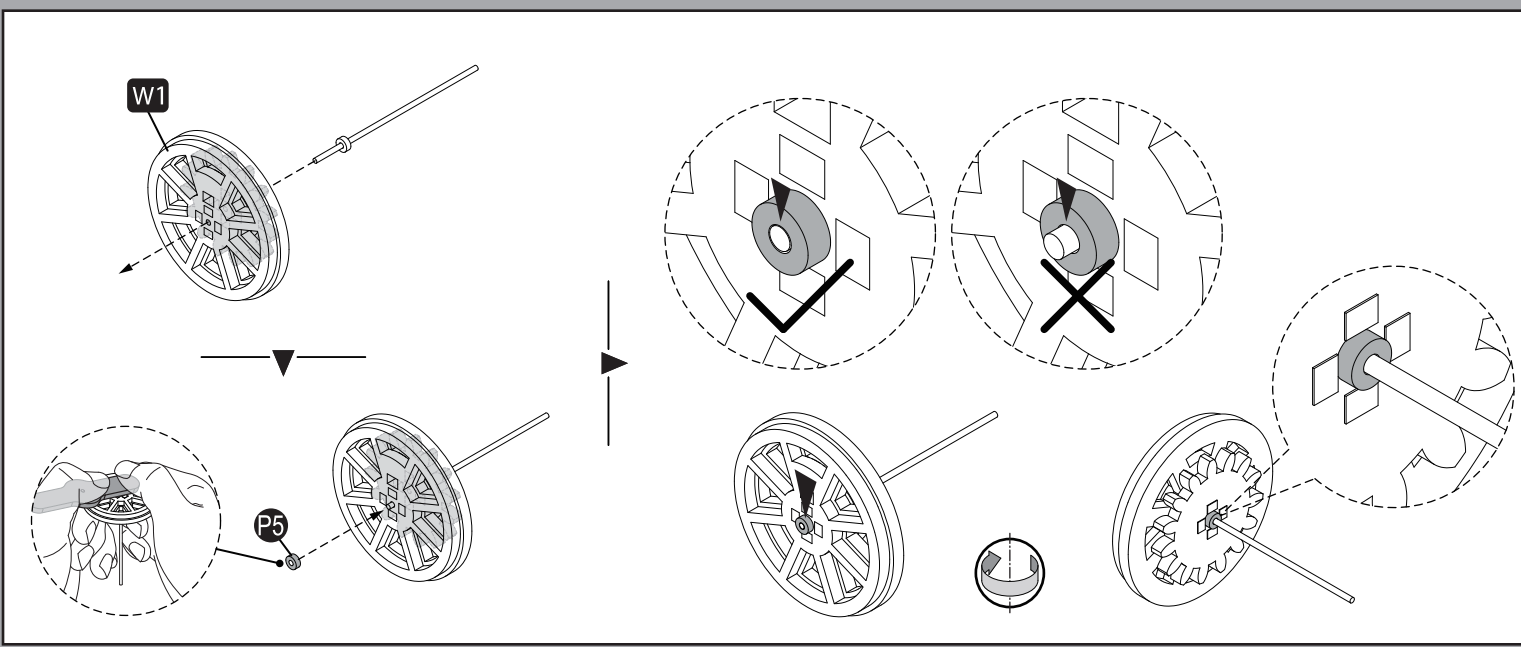

**11**

- C17**x2
- C18**
- C19**x2
- P5**x2

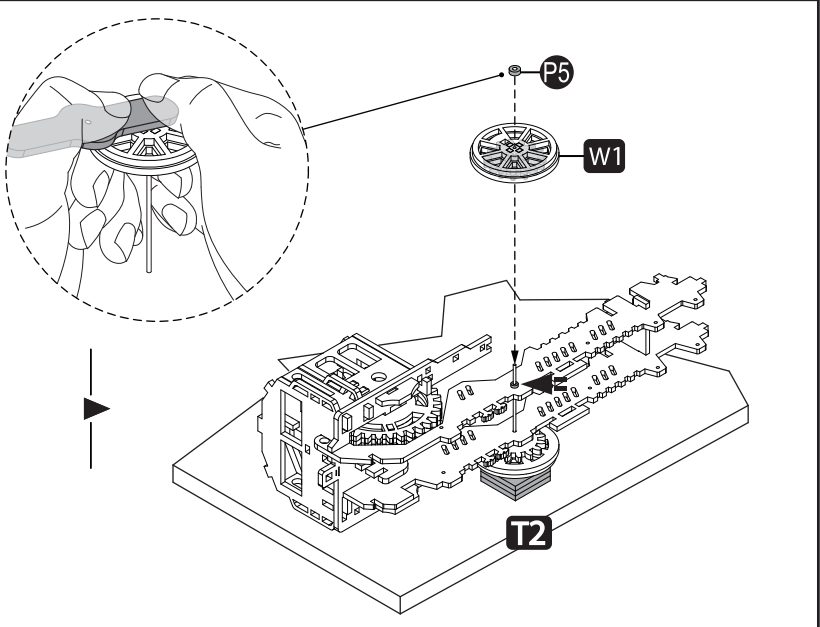
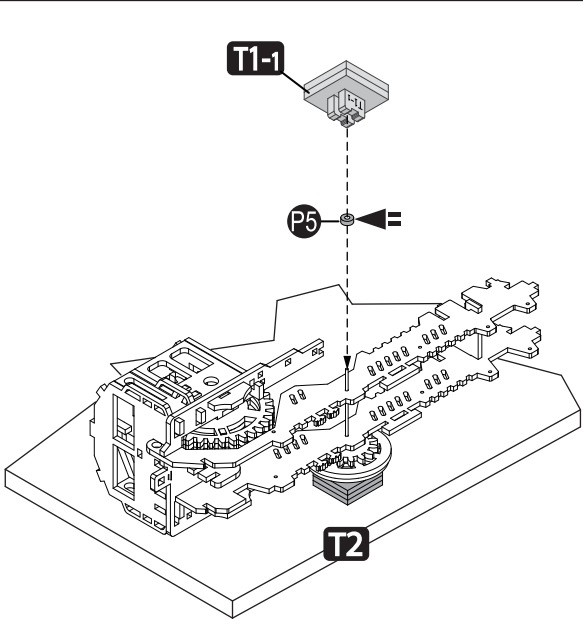
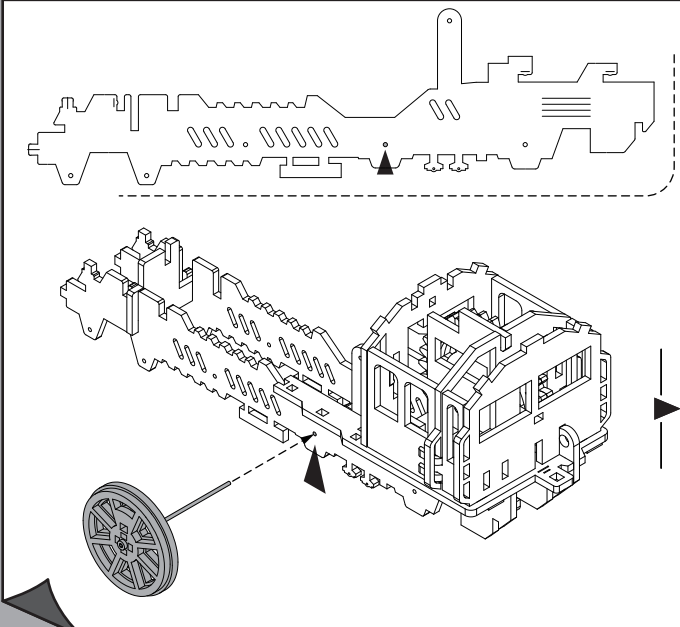
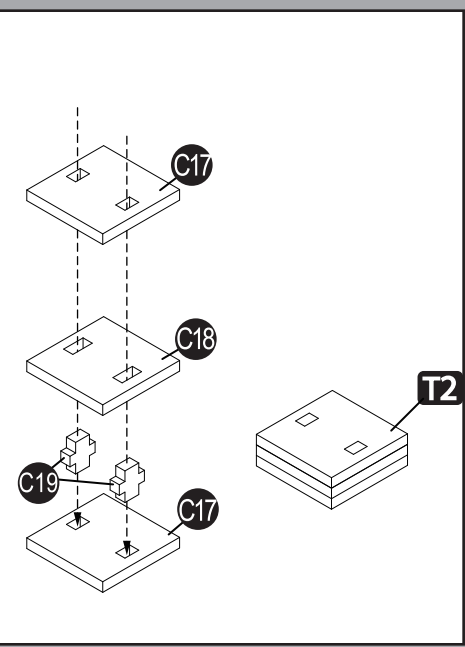



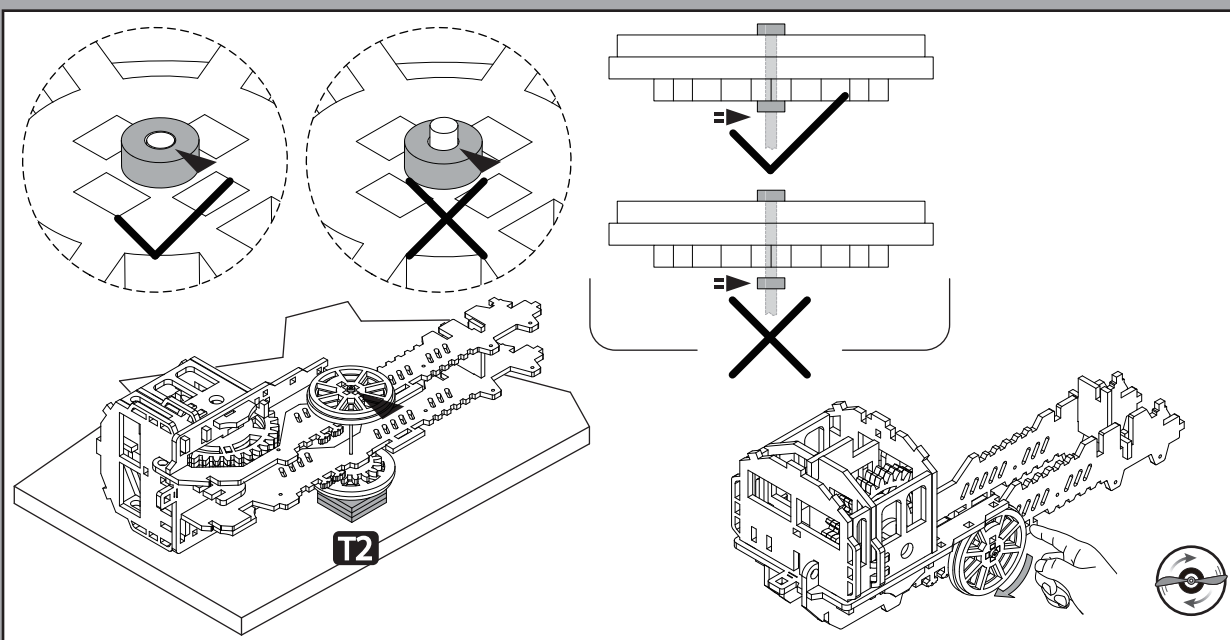

**12**

**10**

P5 x2

P10

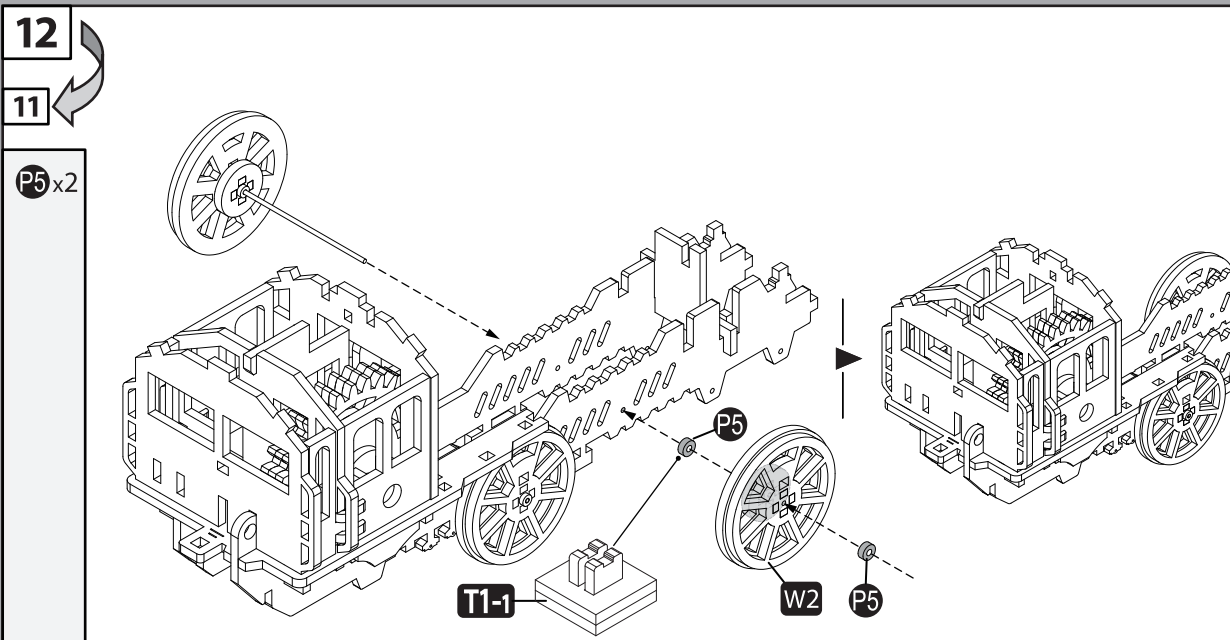
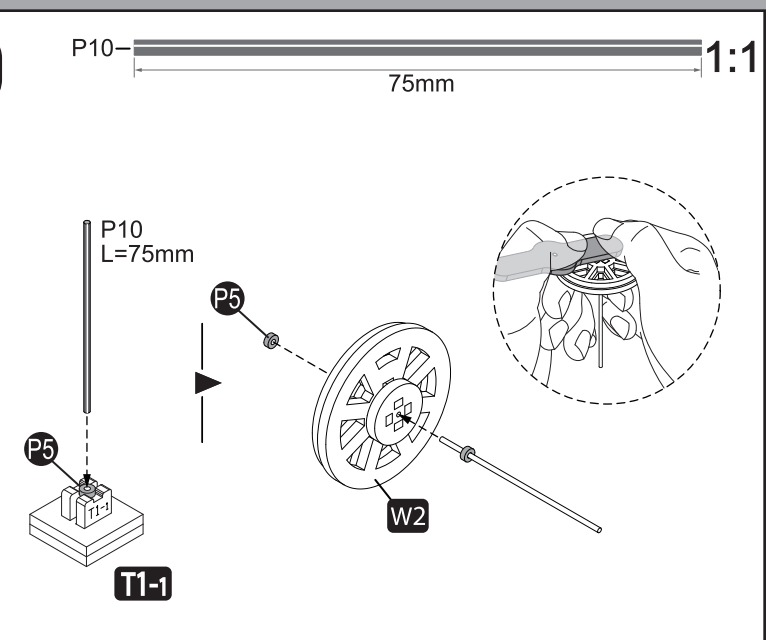

**12**

**11**

P5 x2

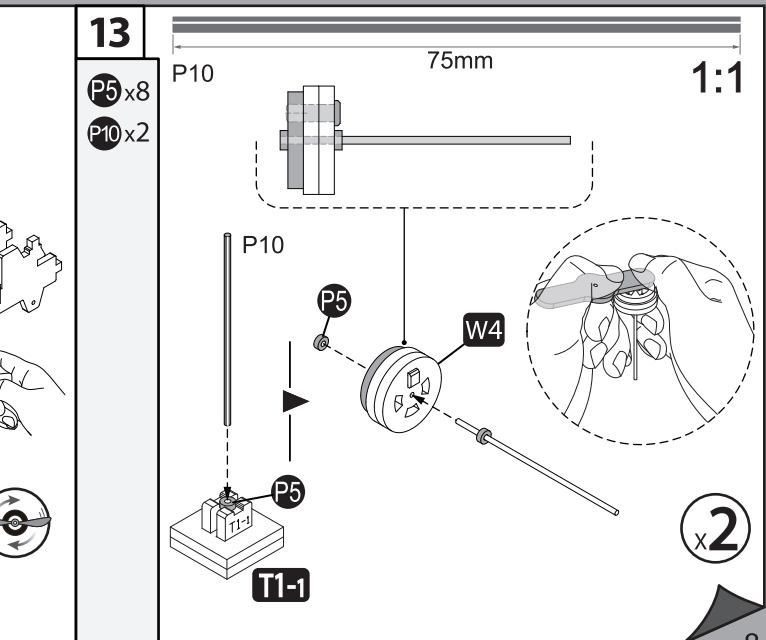

**13**

P5 x8

P10 x2

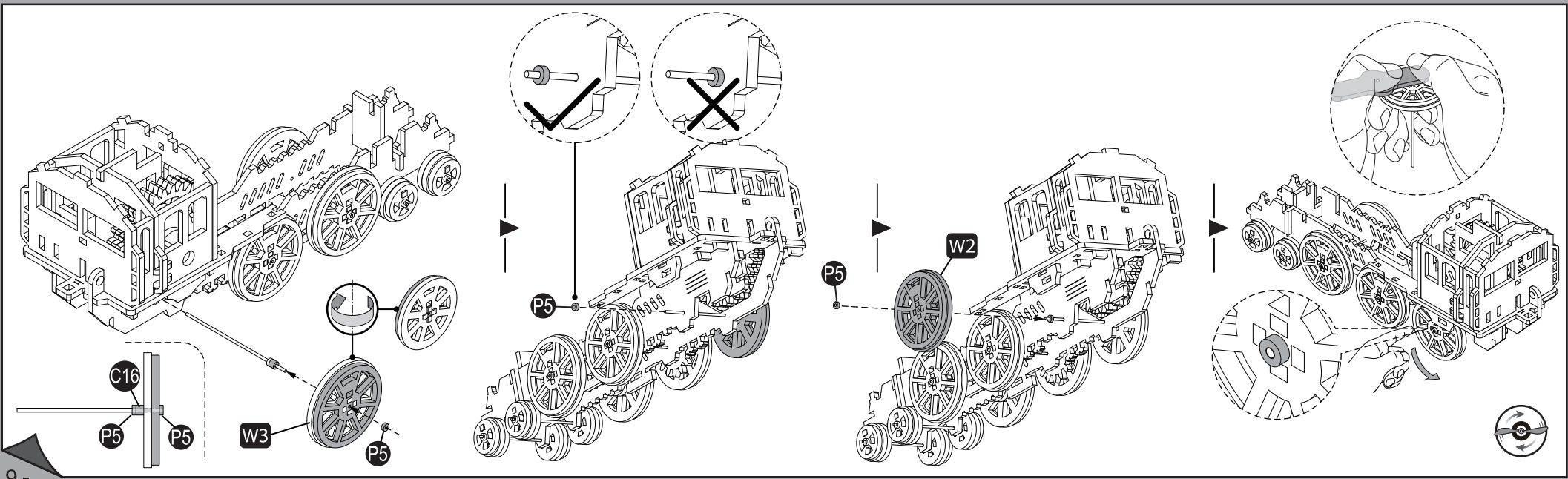
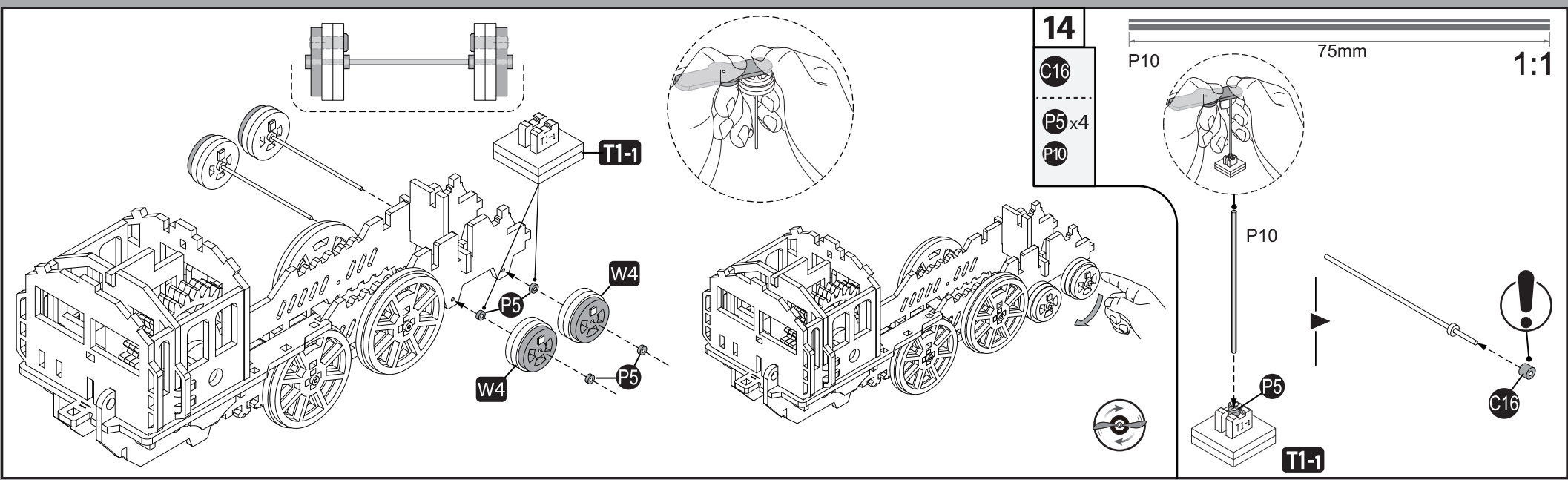

**15**

- C13** x2
- C14** x2
- C15** x2

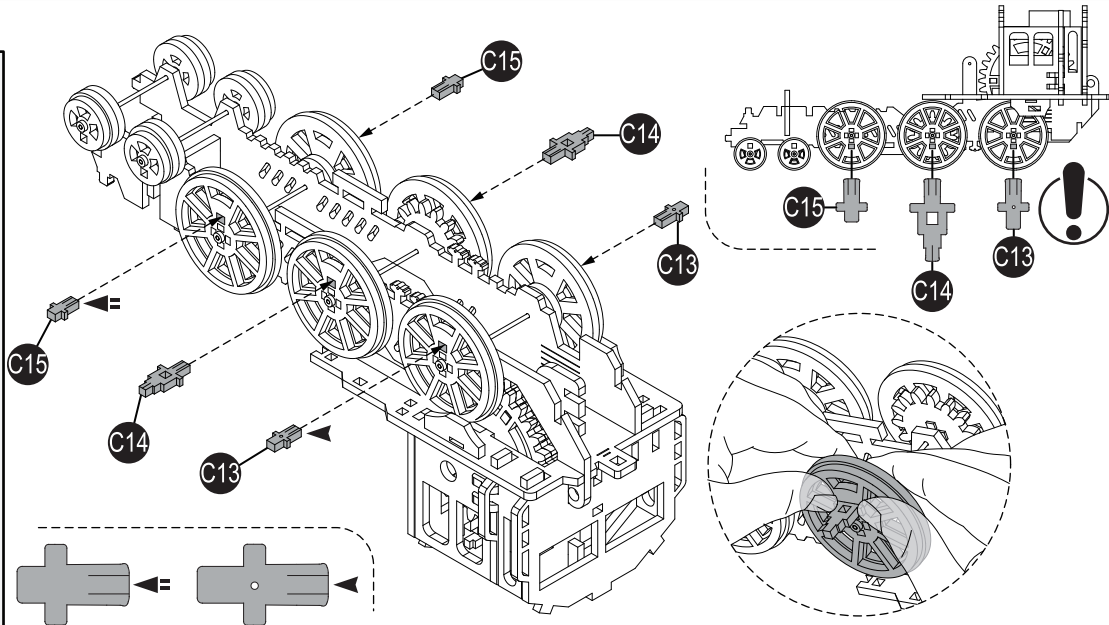
**16**

- B5**
- B6** x2
- B7**
- B8** x2
- B9** x5
- B10**
- B14**

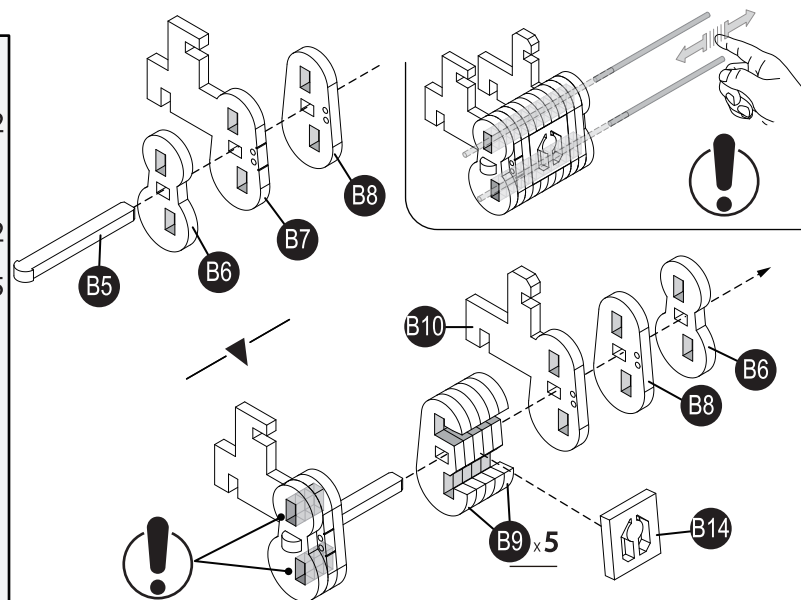

- B5**
- B6** x2
- B8** x2
- B9** x5
- B13**
- B14**
- B15**

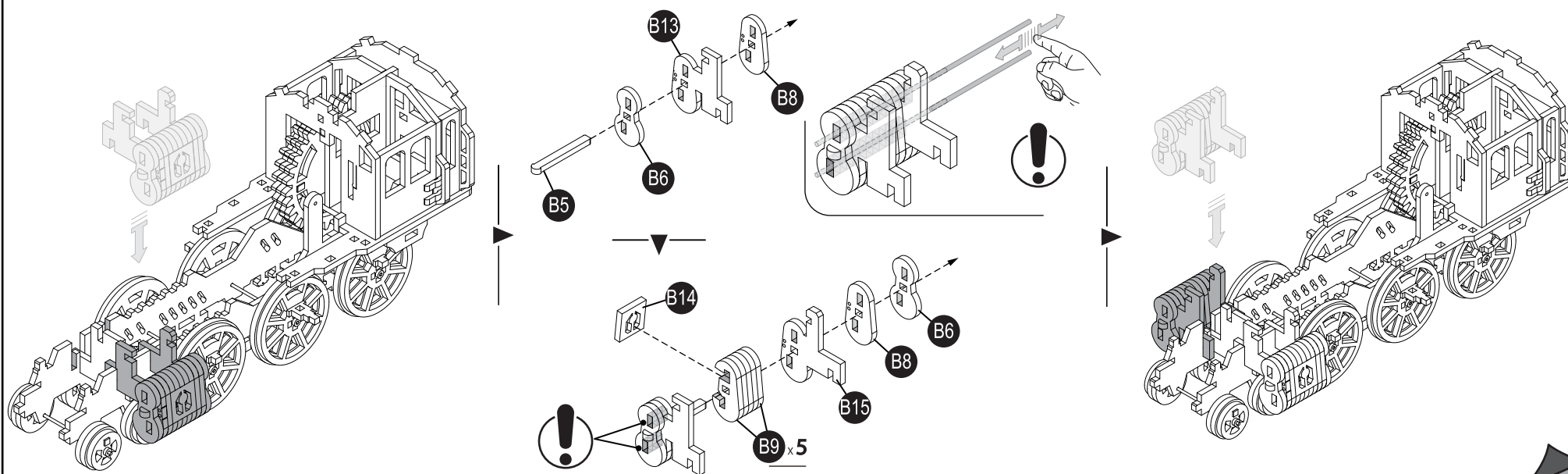

17

B11

B12

D1

D2

D3

D4

D5

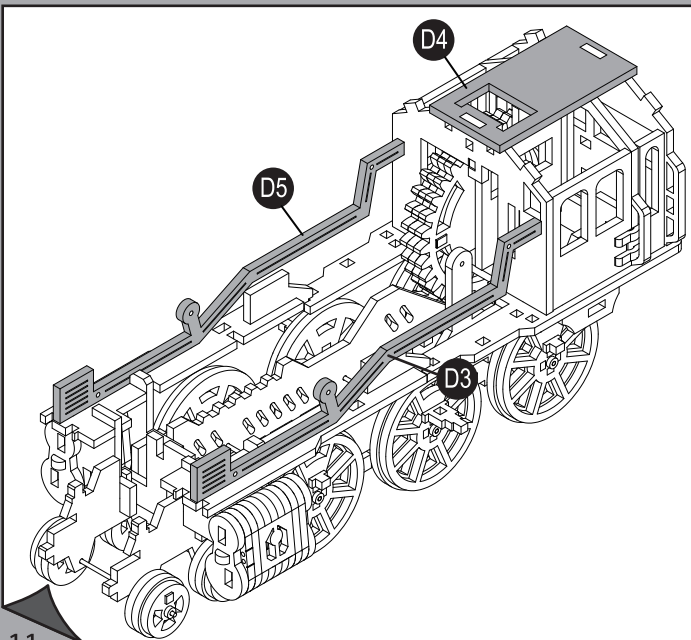
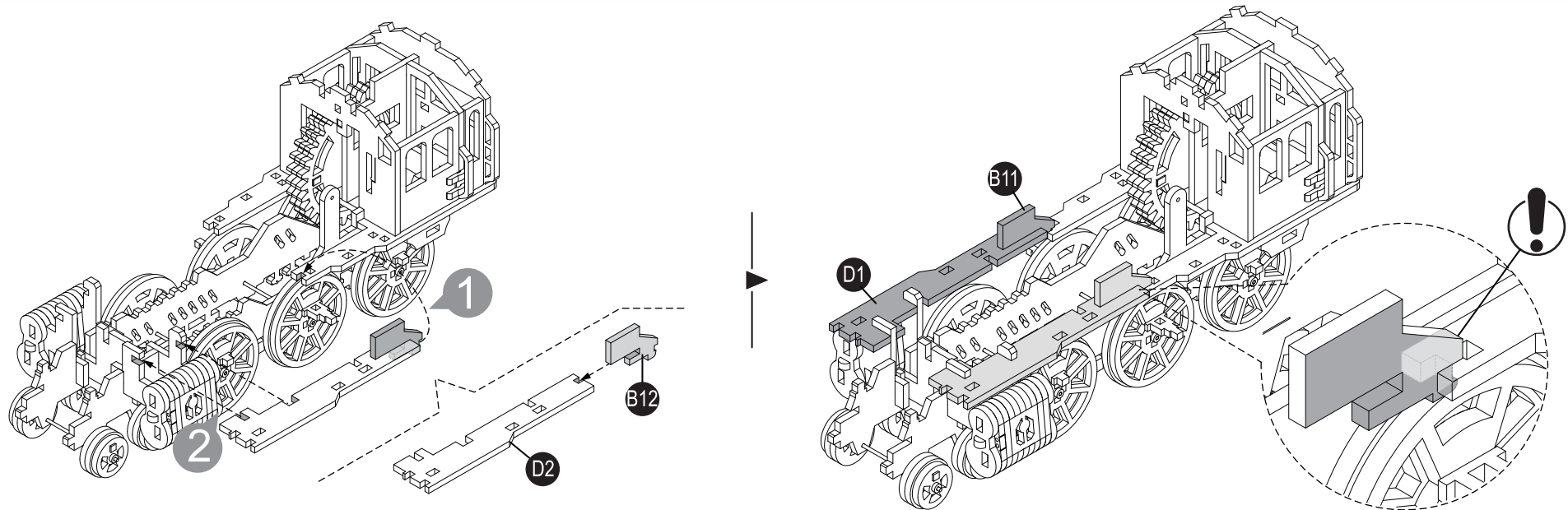

18

D6

D7 x2

D8

D9

D10 x3

D11

D12

D13

P7

P7 — 30mm — 1:1

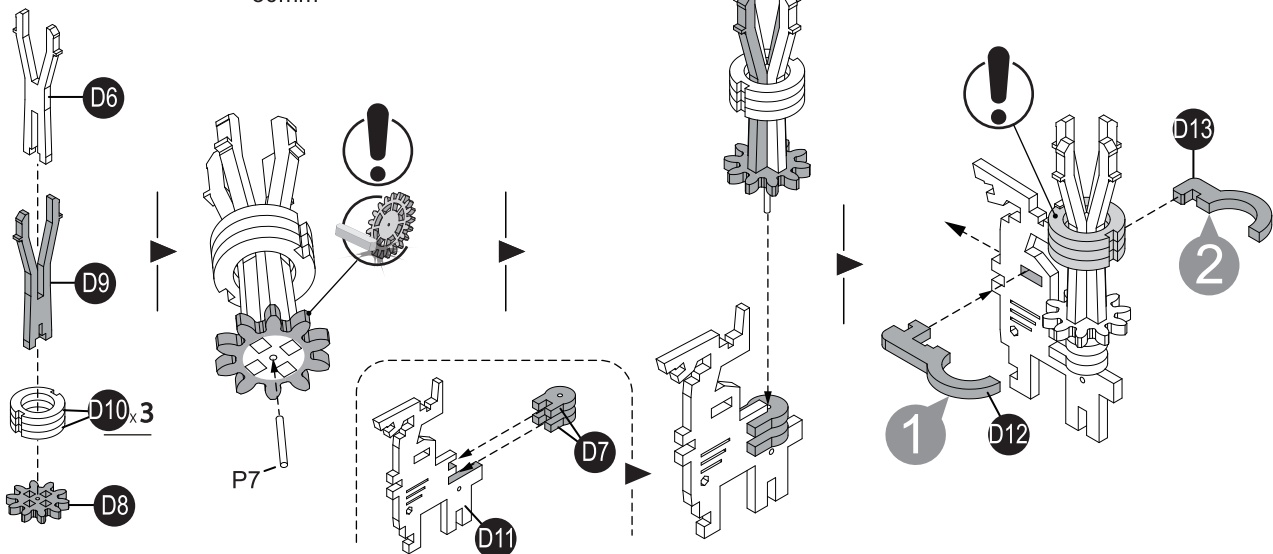

- D14 x2
- D15
- D16
- D17
- P5 x4
- P8

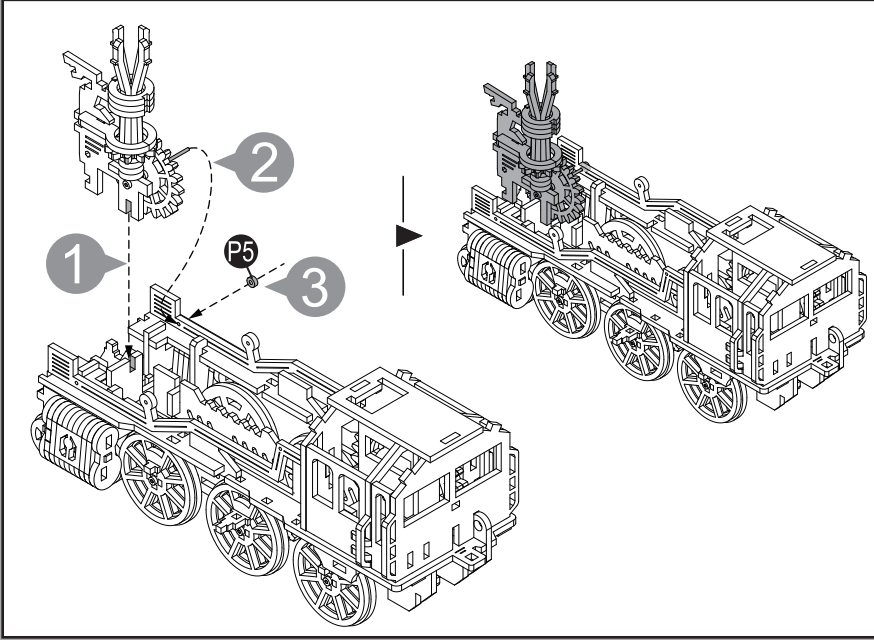
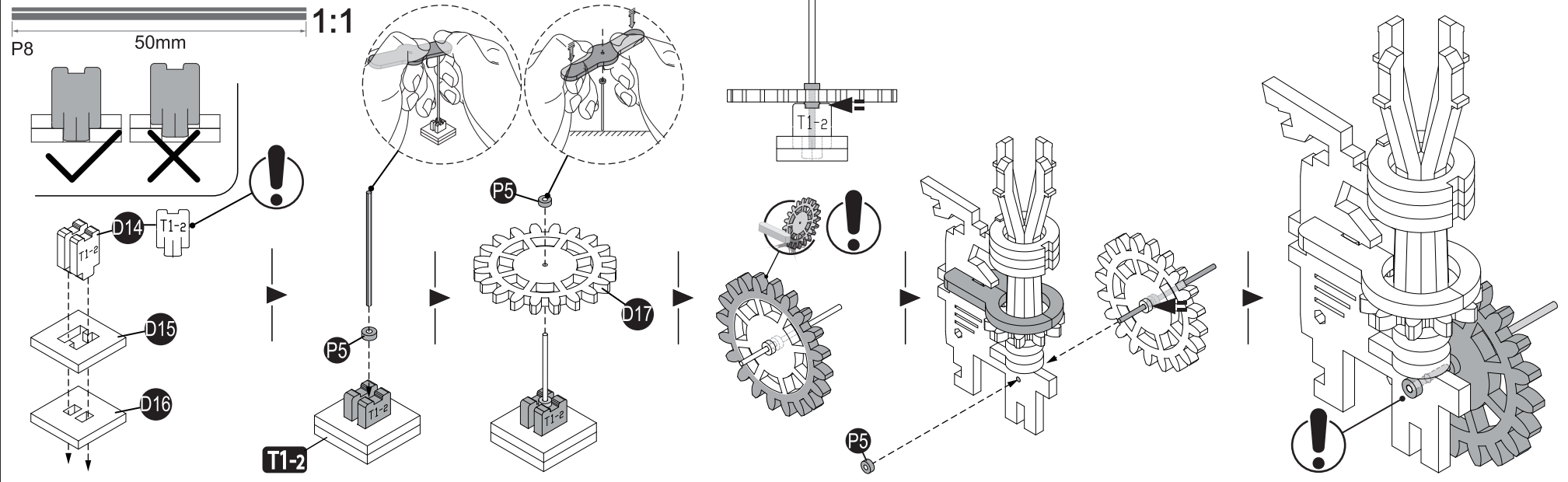

- 19
- D18 x2
  - D19 x4
  - D20 x4
  - D21

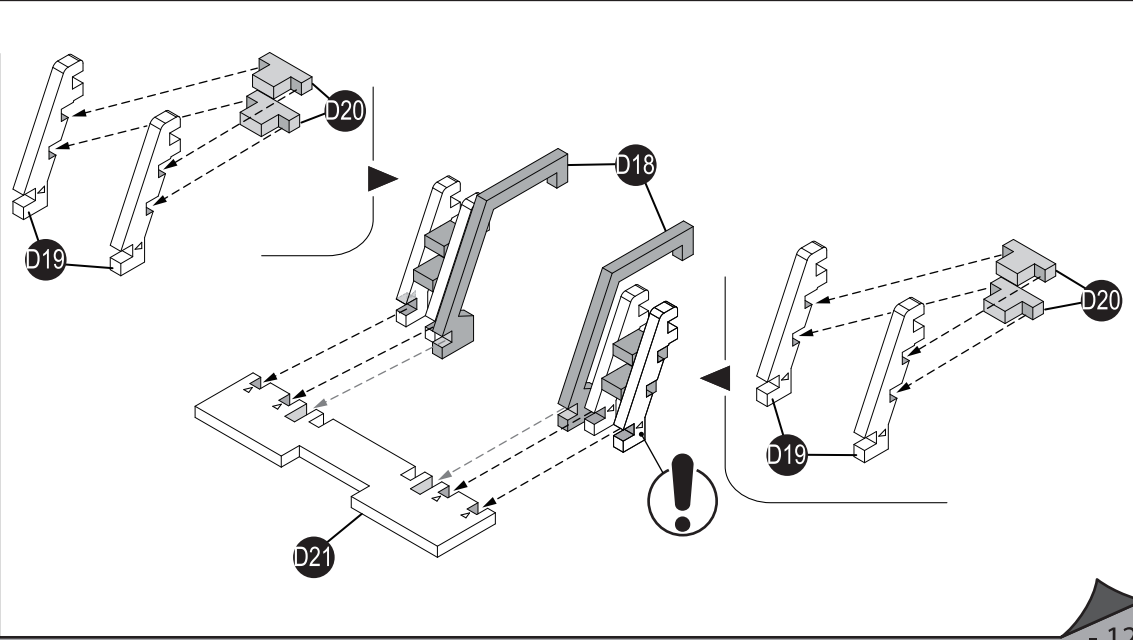

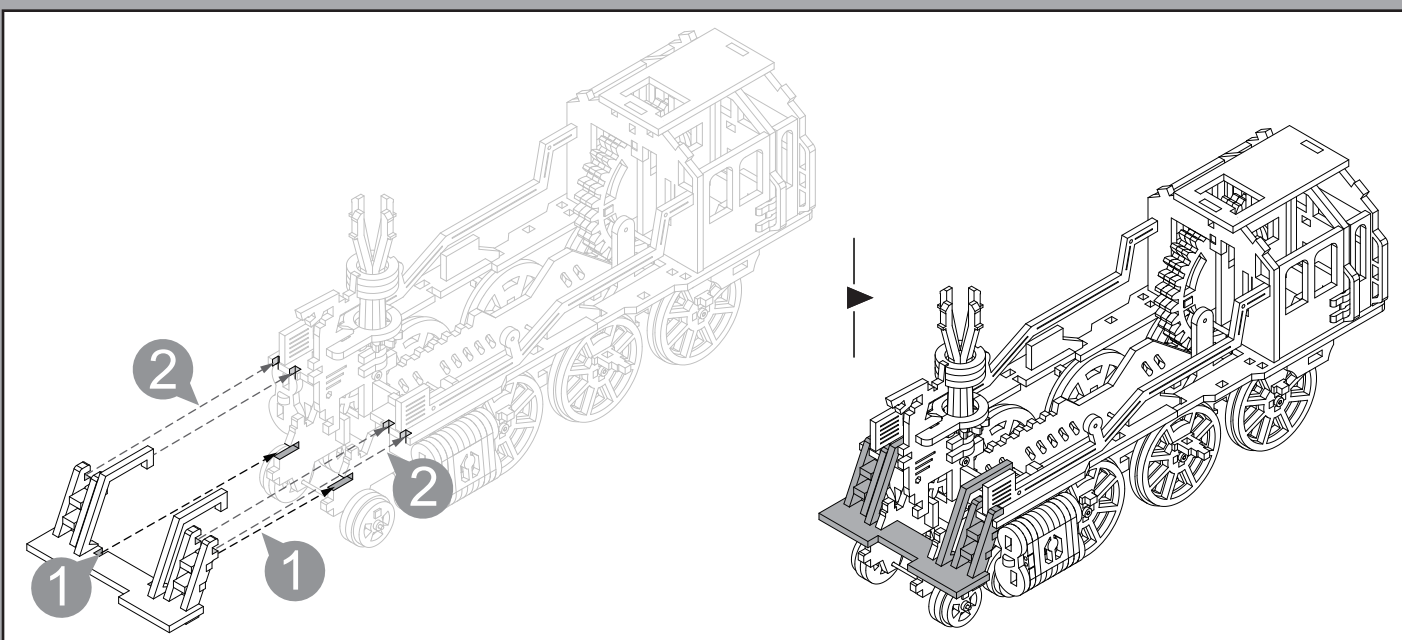

- 20**
- D22 x2
  - D23
  - D24
  - D25
  - D26

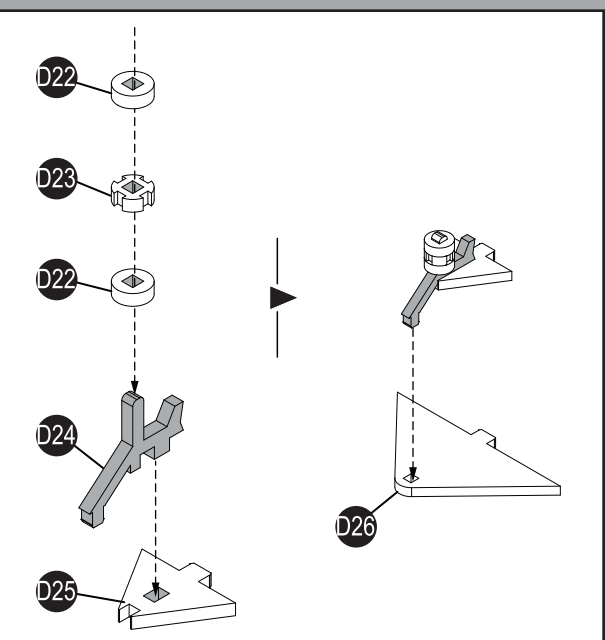

- D27
- D28 x2
- D29 x2
- D30

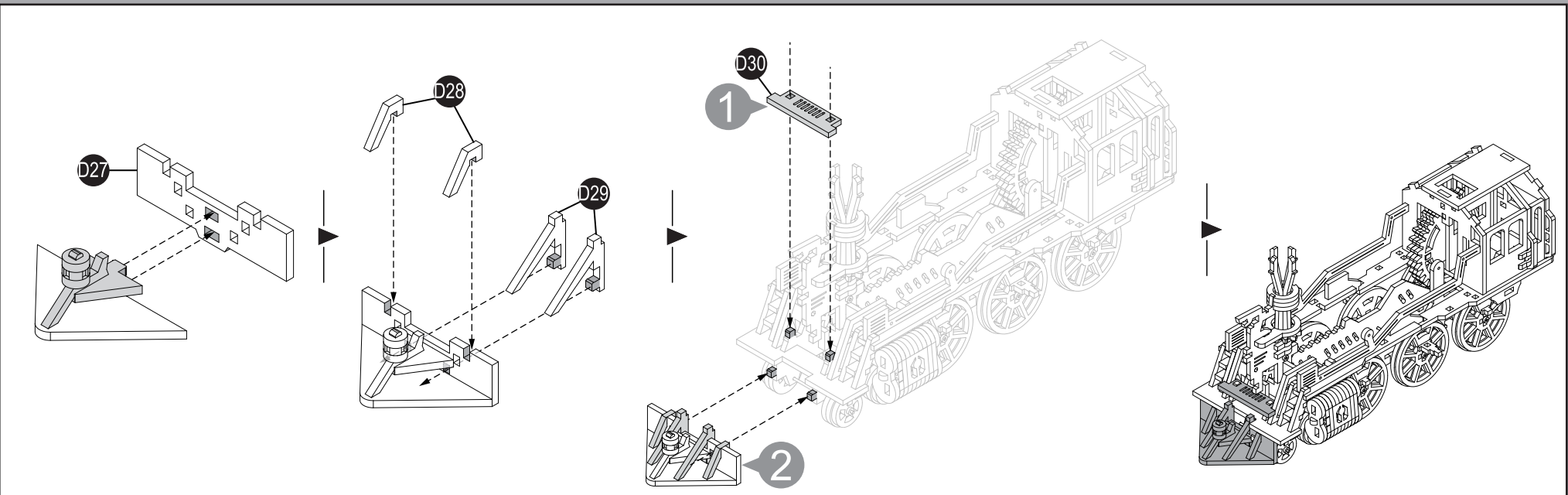

**21**

- D31
- D32
- D33
- E1
- E2
- E3 x2
- E4
- E5
- E6
- E7 x2
- P5 x2
- P7

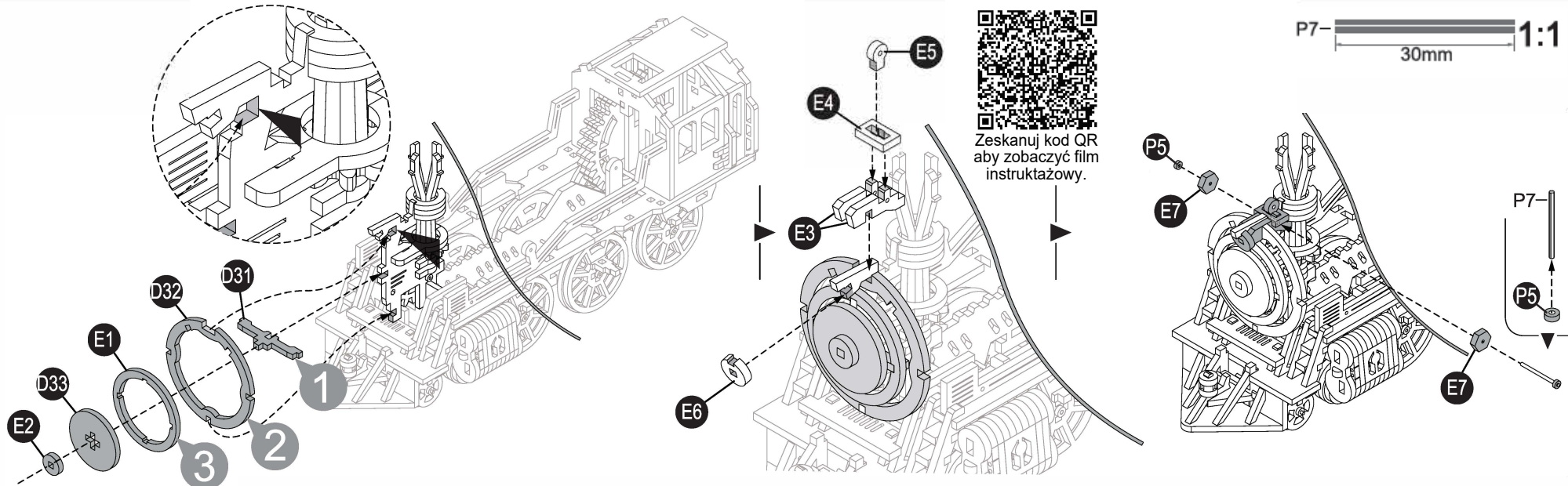
**22**

- E8
- E9
- E10 x2
- E11 x2
- E12 x2
- E13 x2
- E14
- P5 x4
- P11

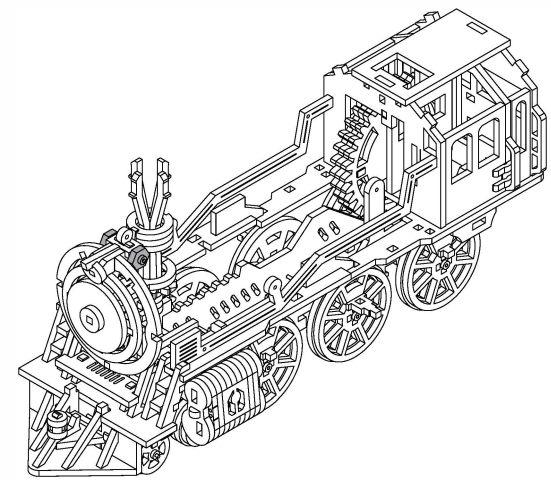
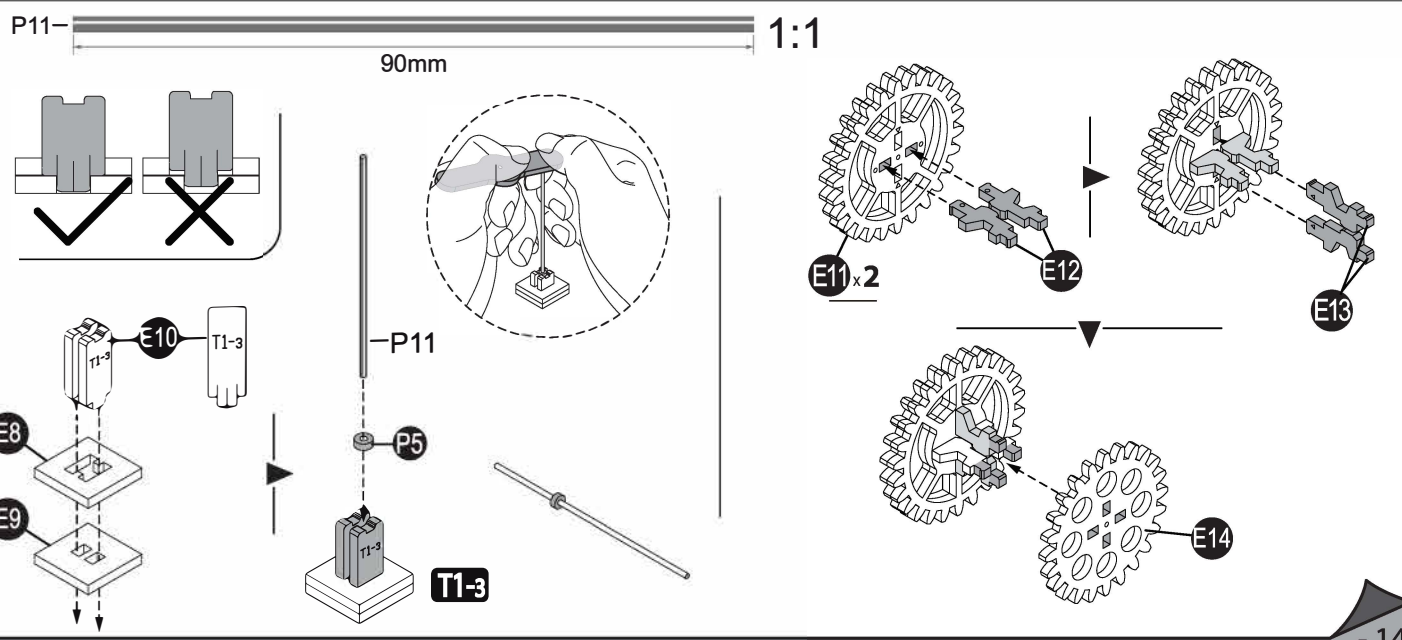

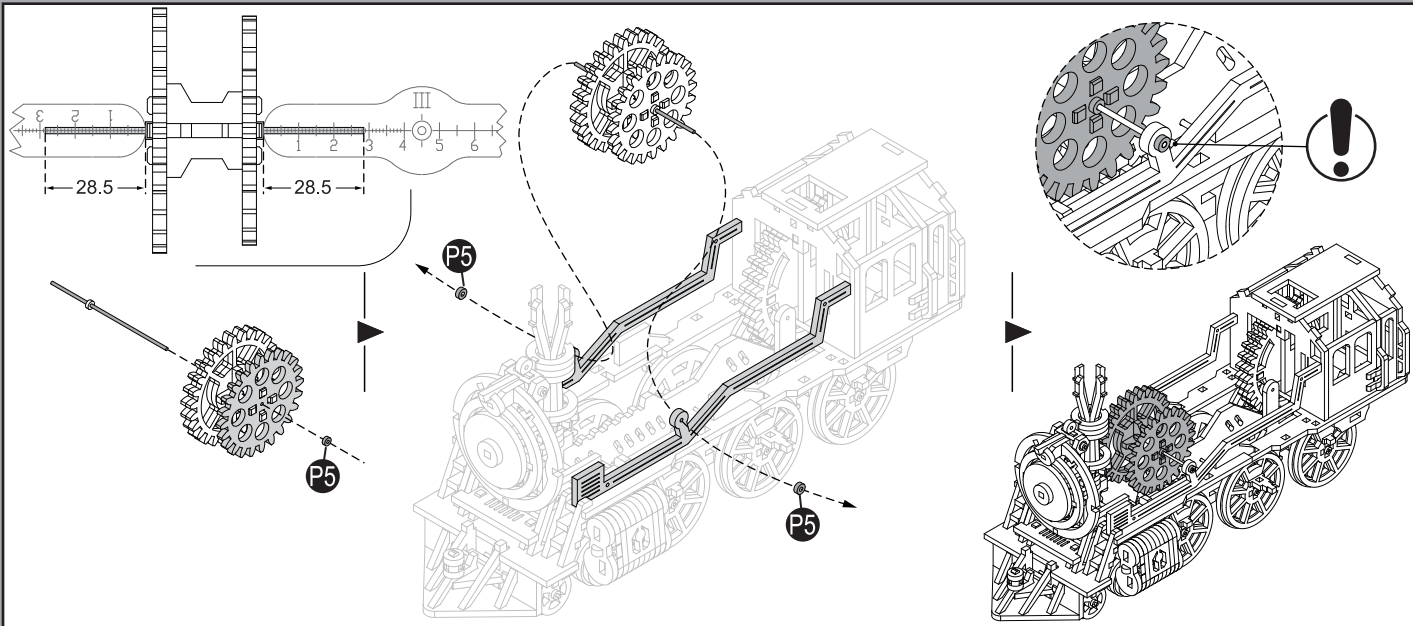

- 23**
- (E8)
  - (E9)
  - (E15x2)
  - (P5)
  - (P9)

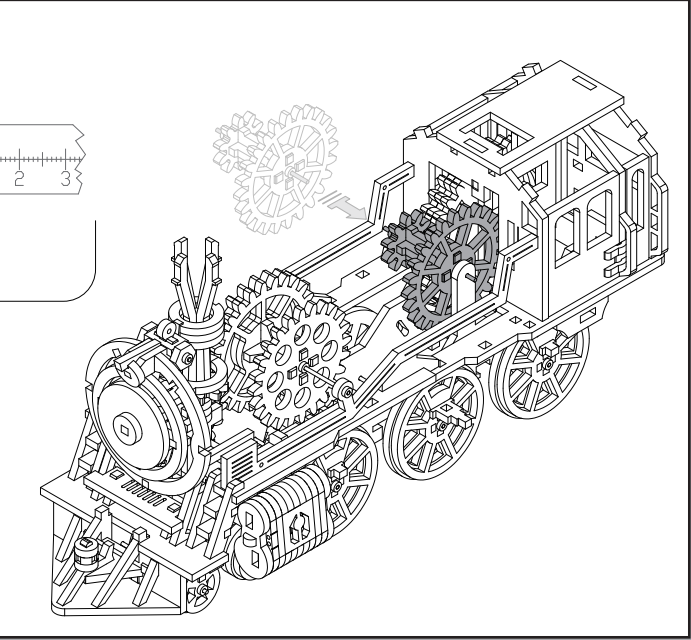
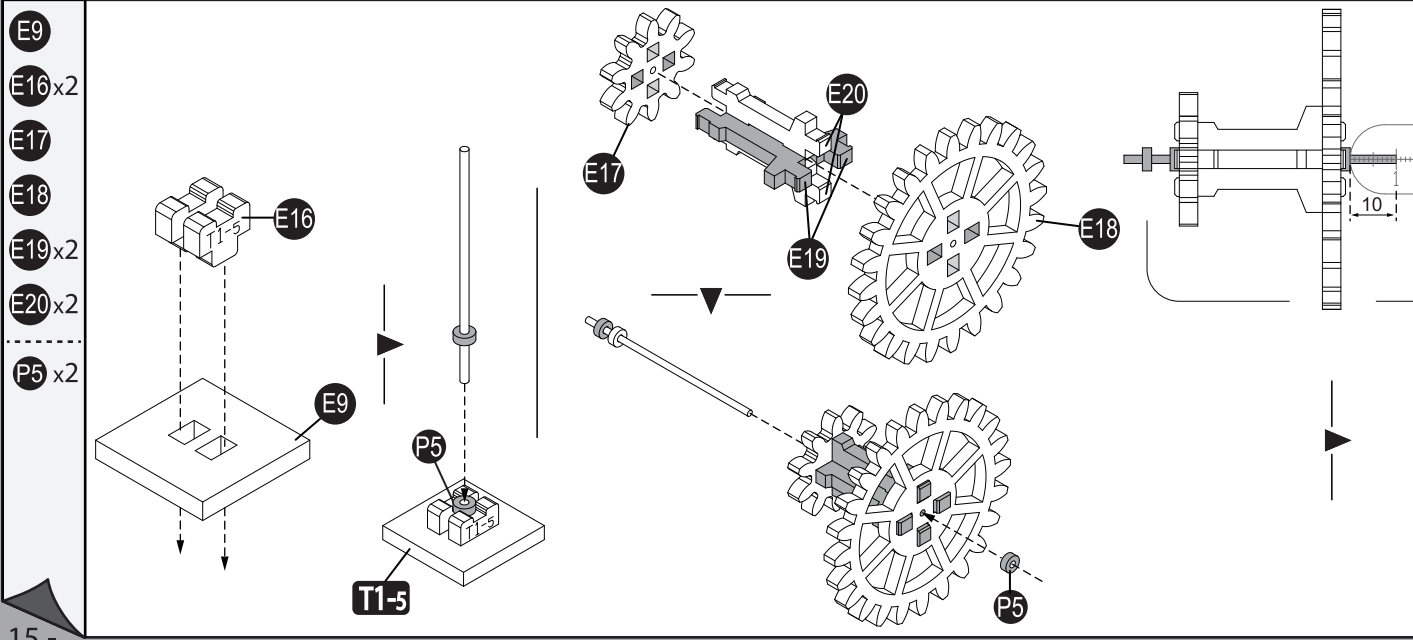
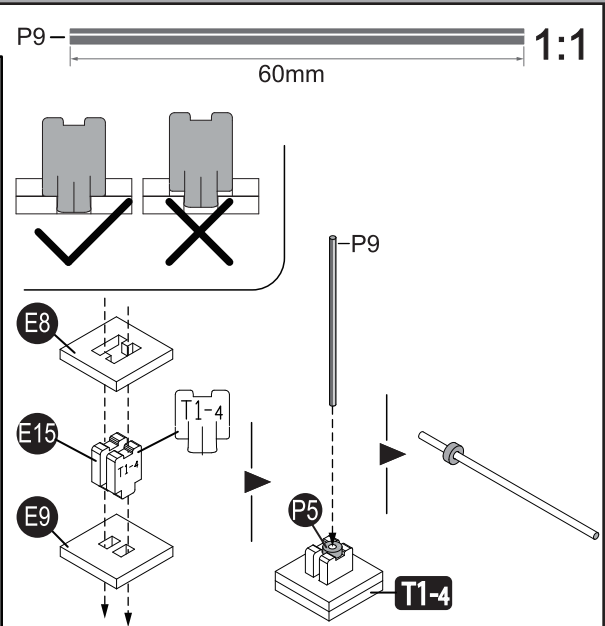

- (E9)
- (E16x2)
- (E17)
- (E18)
- (E19x2)
- (E20x2)
- (P5 x2)



- E21
- E22 x2
- E23 x2
- E25 x2
- E26 x2
- P10

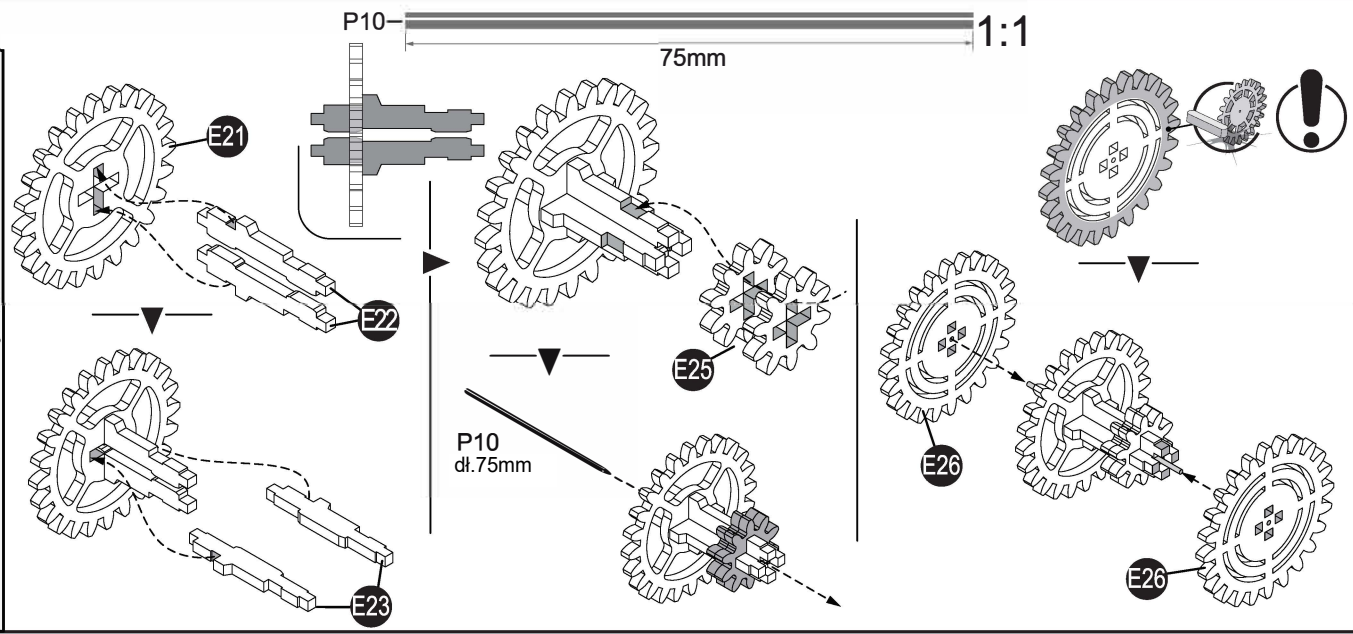

- E8
- E9
- E24 x2
- E28
- E29
- F1
- P5 x2

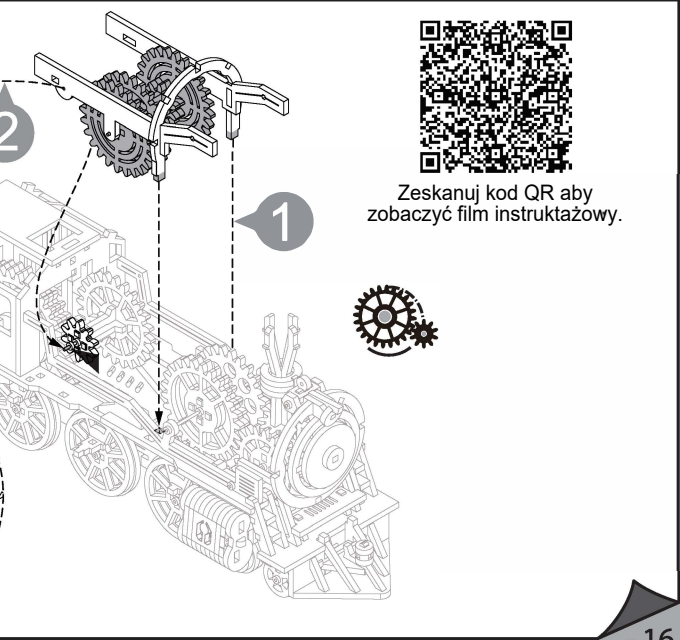
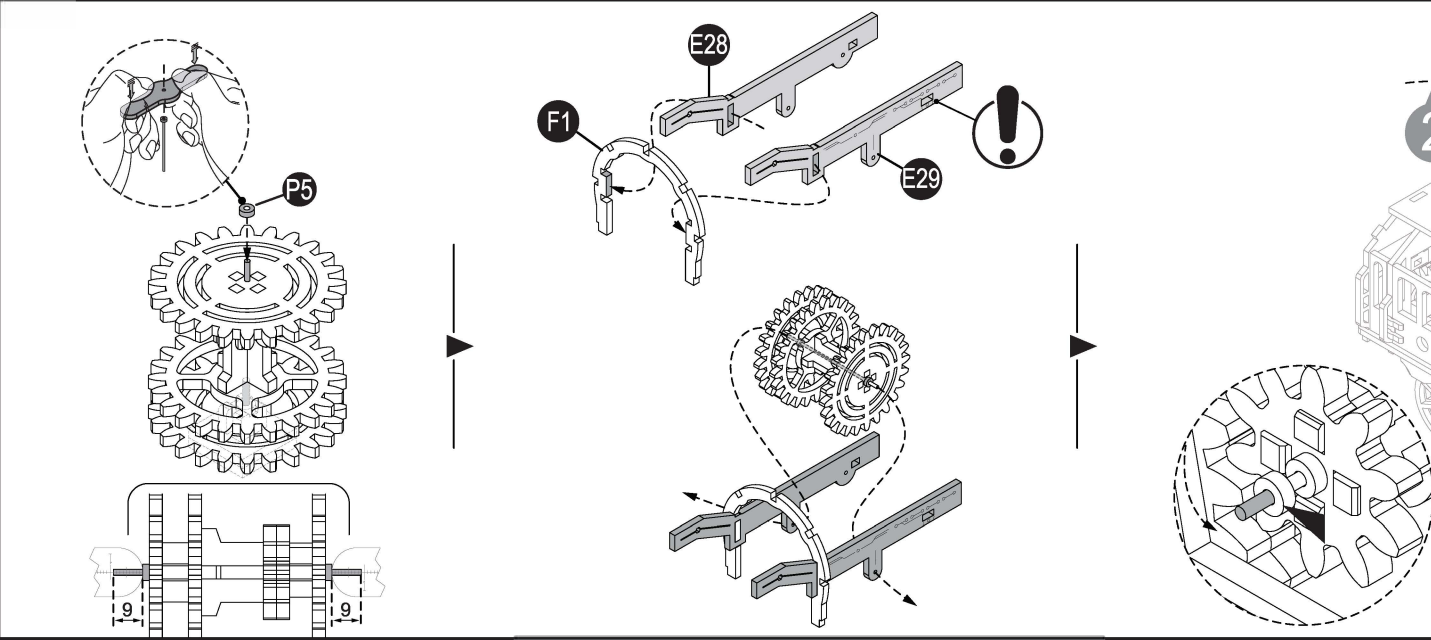
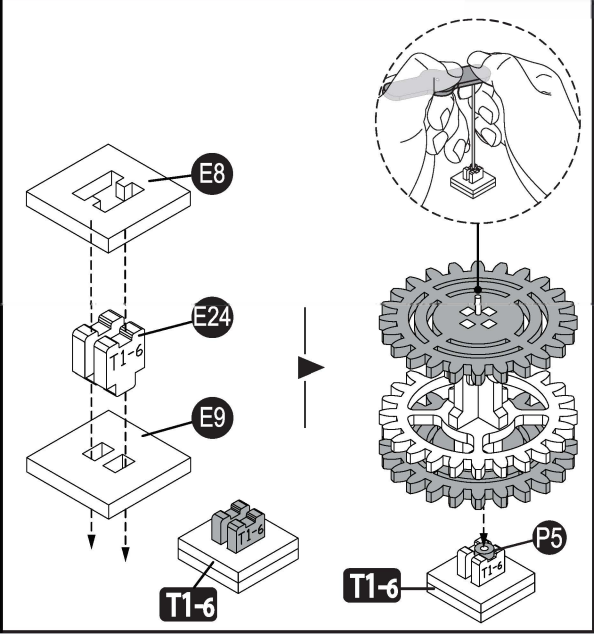

Zeskanuj kod QR aby zobaczyć film instruktażowy.

E27 x2

F2

F3

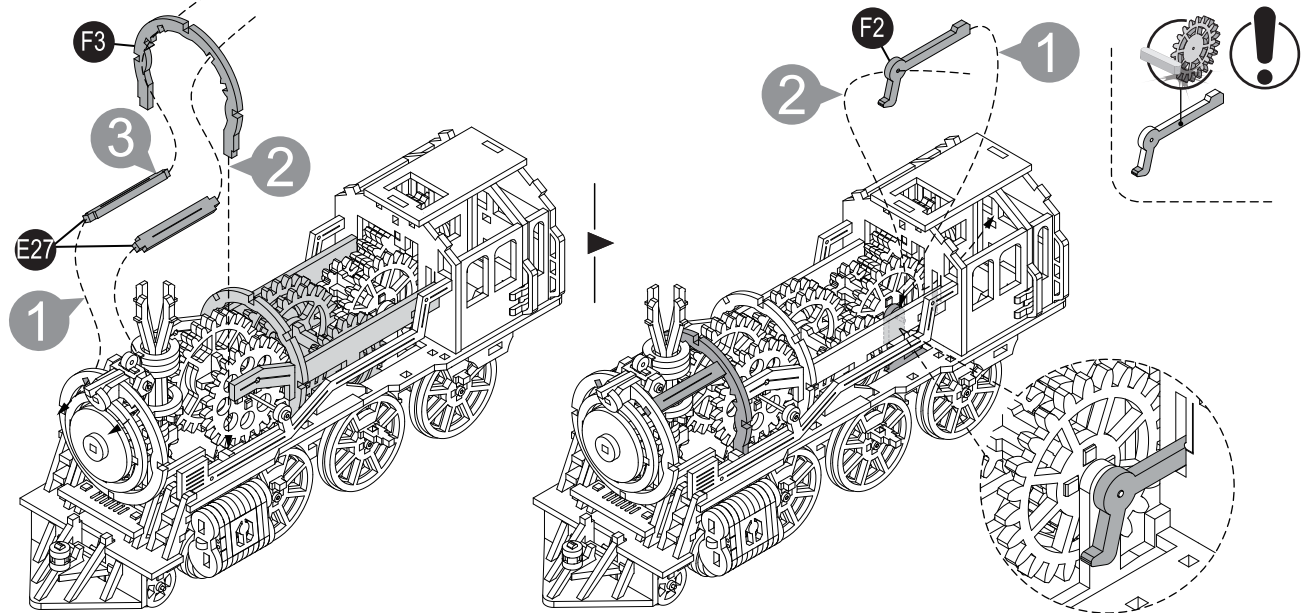

25

F4

F5

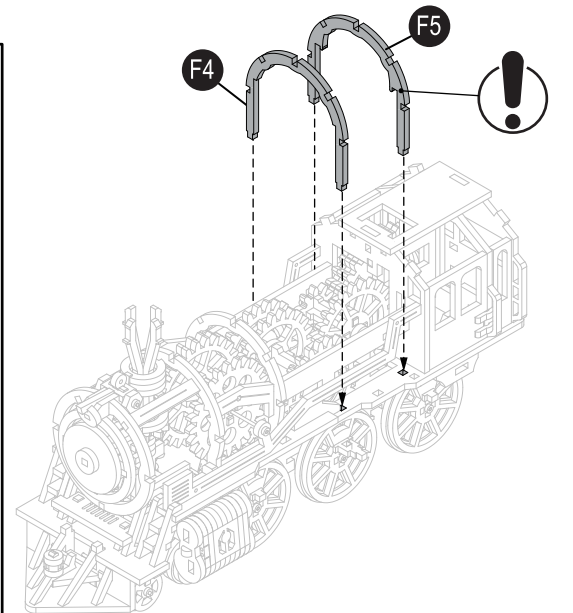

F6

F7

F8

F9

F10

F11 x2

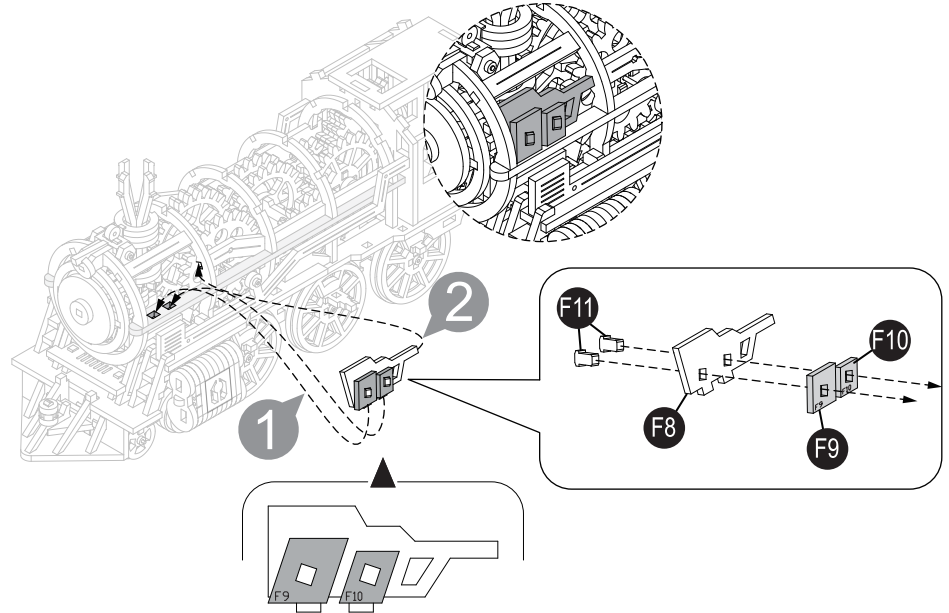
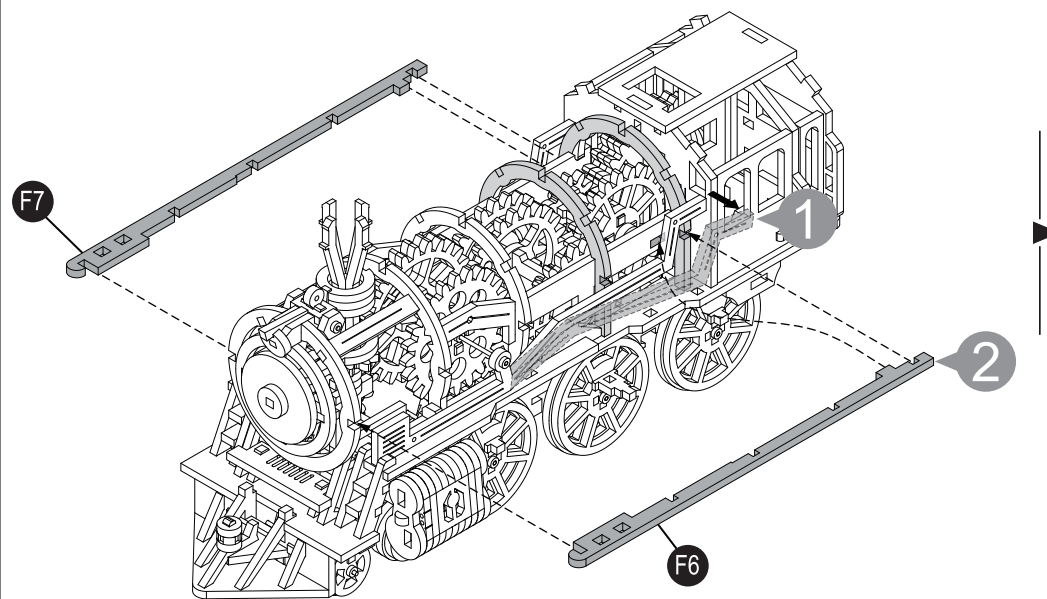

F11 x2

F13

F14

F15

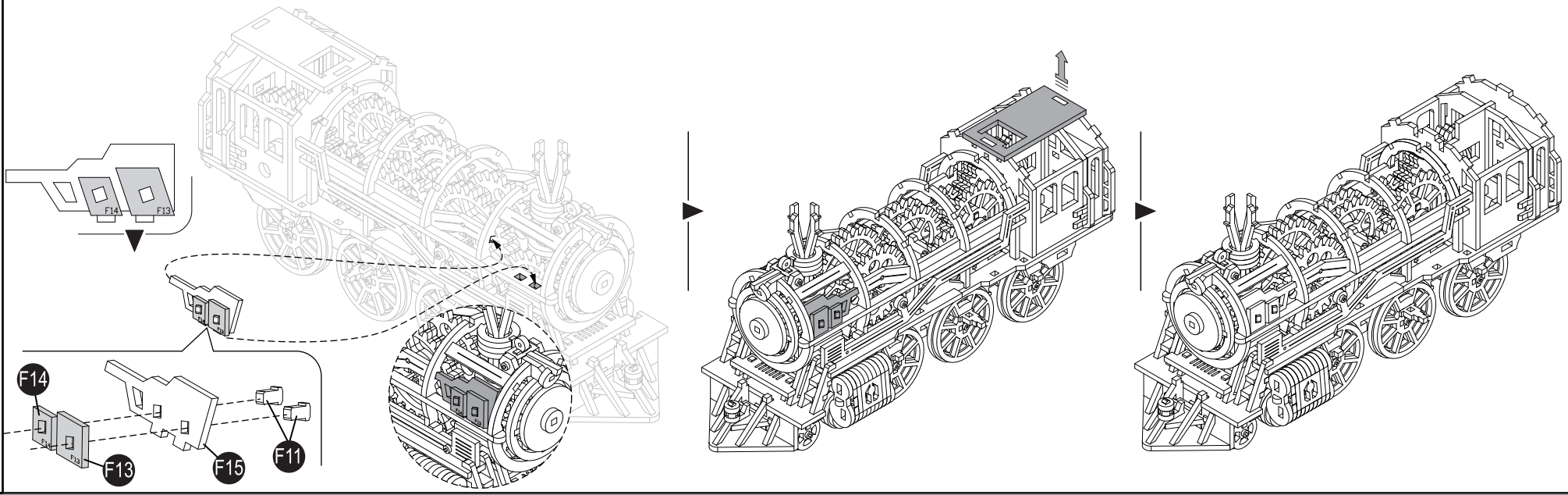

26

F12

F16

F17

F18

F19

F20

F21 x4

F22

F23

F24

H1

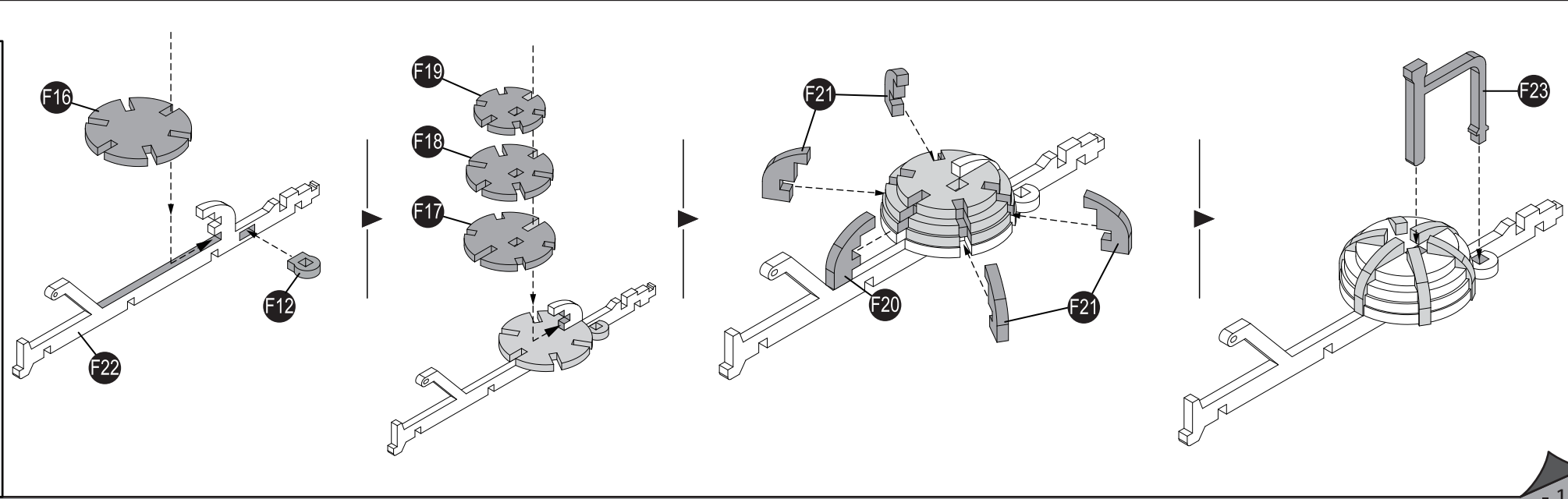

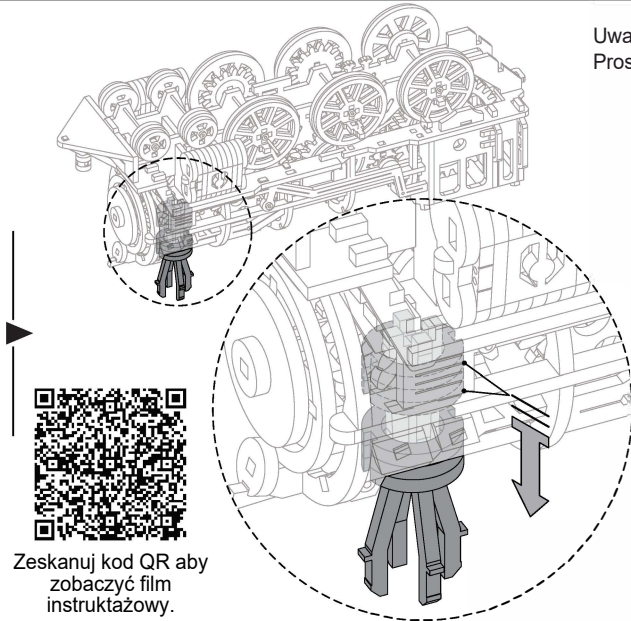
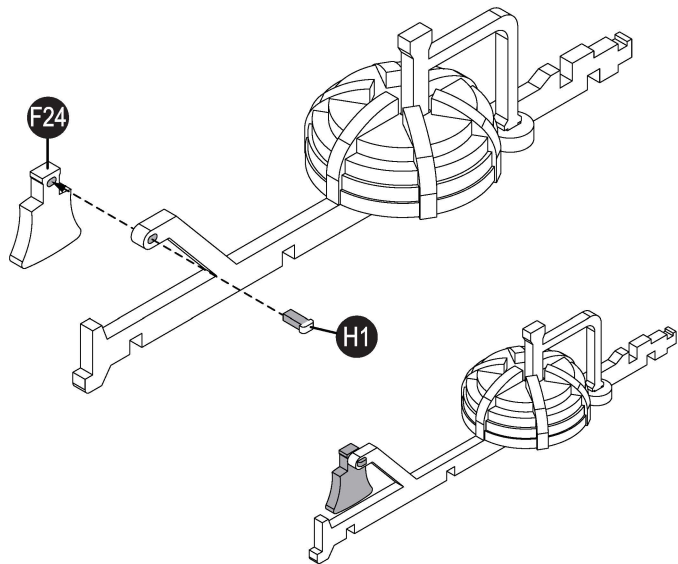

Uwaga:  
Proszę obrócić model i wyjąć część D10 do montażu później.

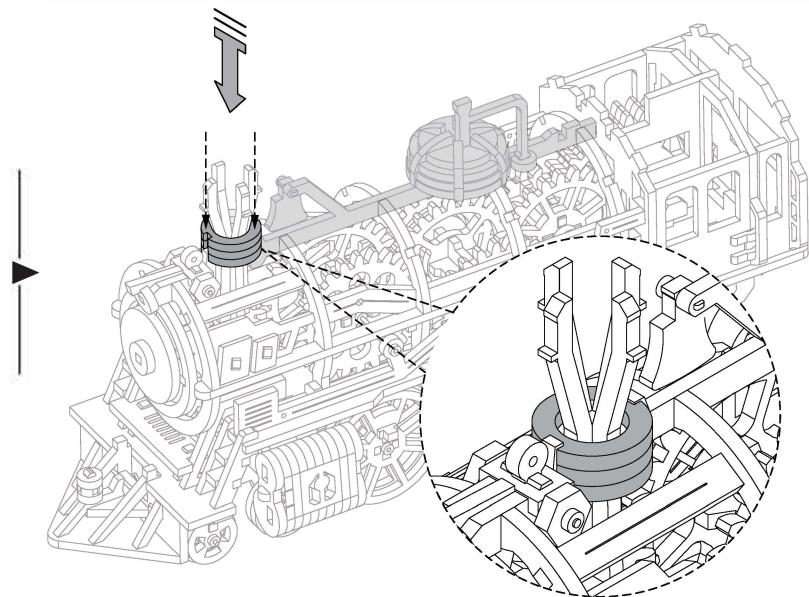
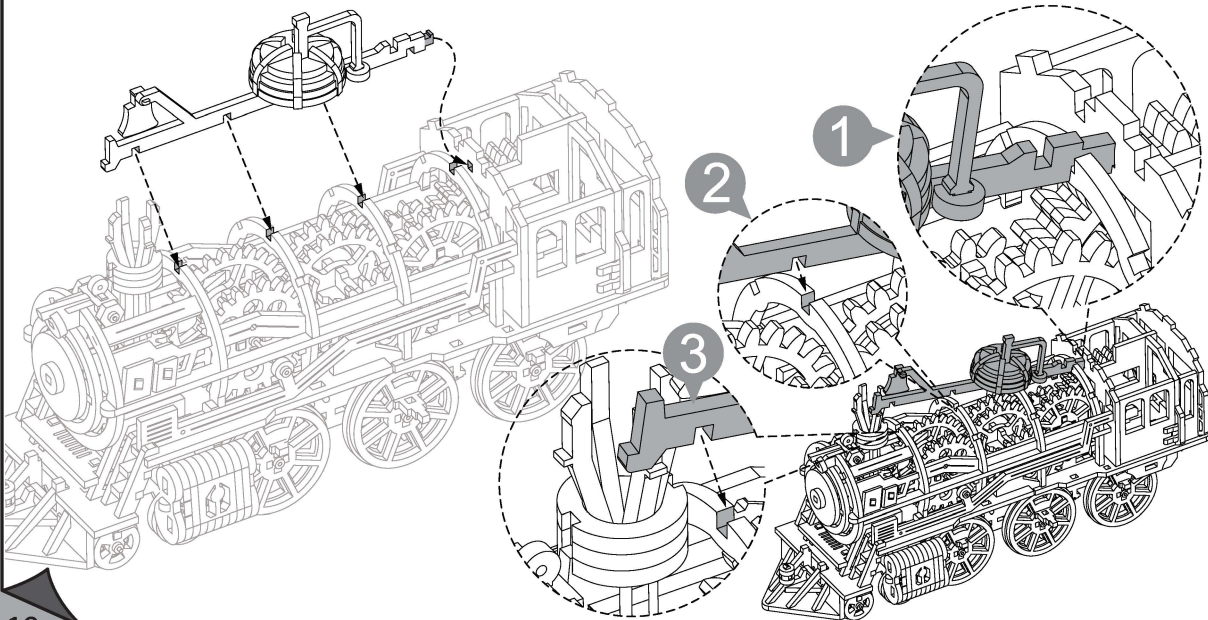
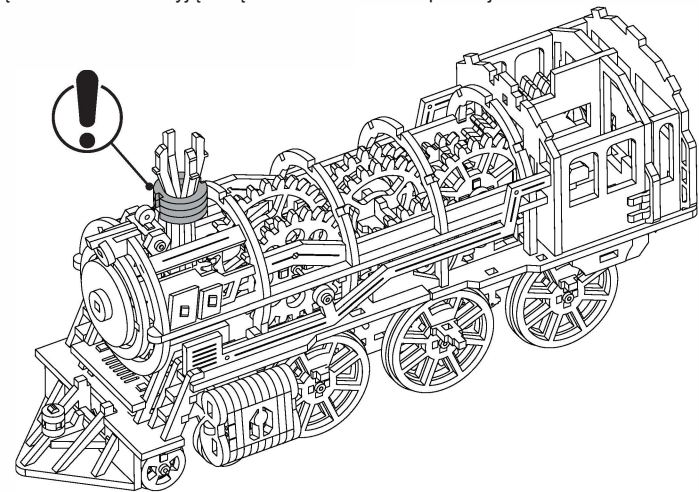

F25x2

F26x2

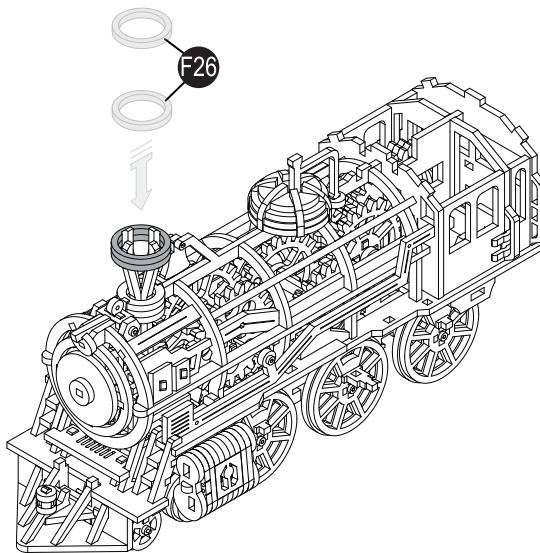
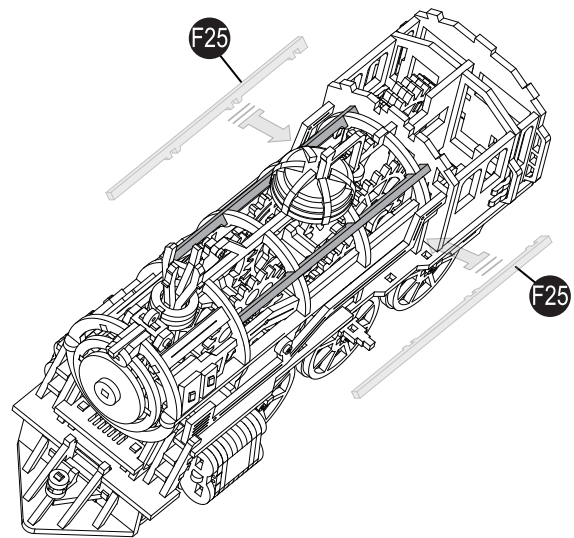

27

F29

F30

F31

P5x4

P6x2

P6 ————— 1:1  
15mm

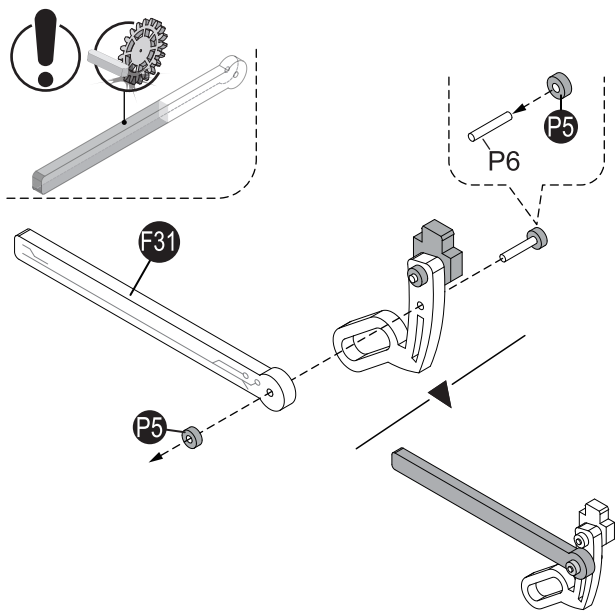
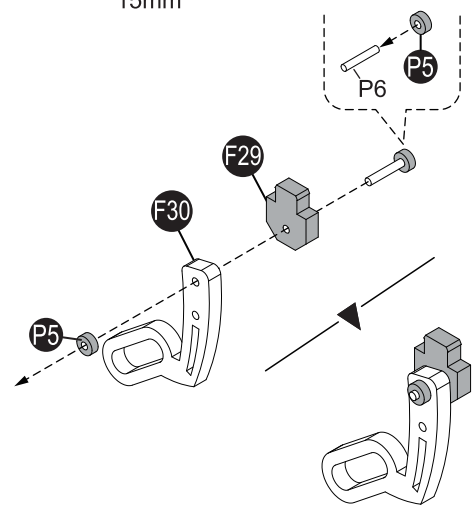

F27

F28

F32

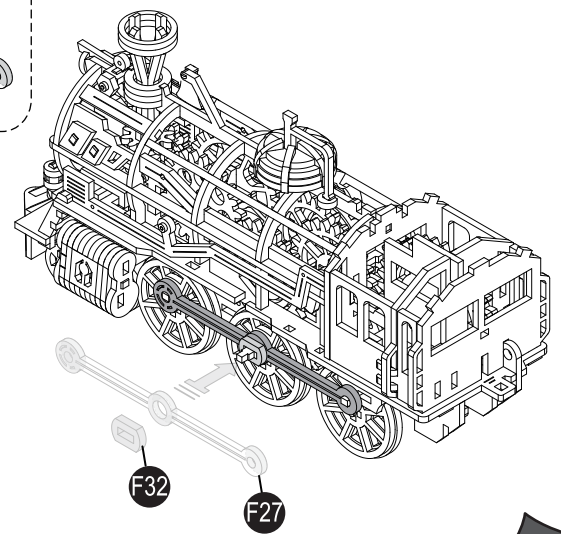
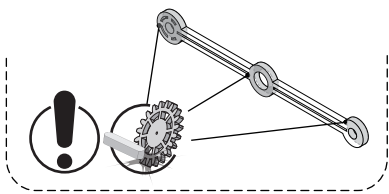
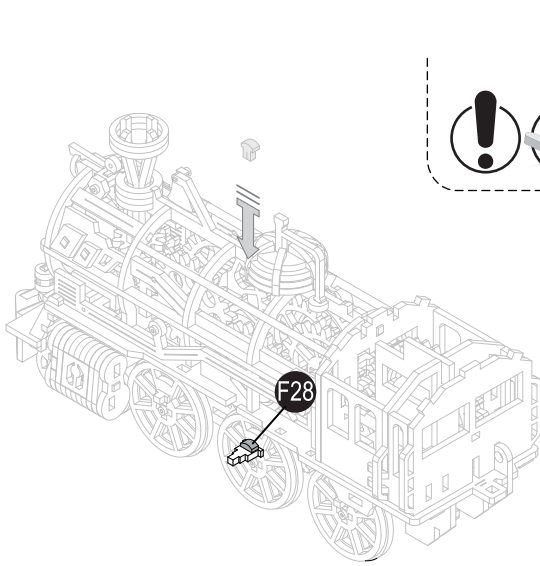

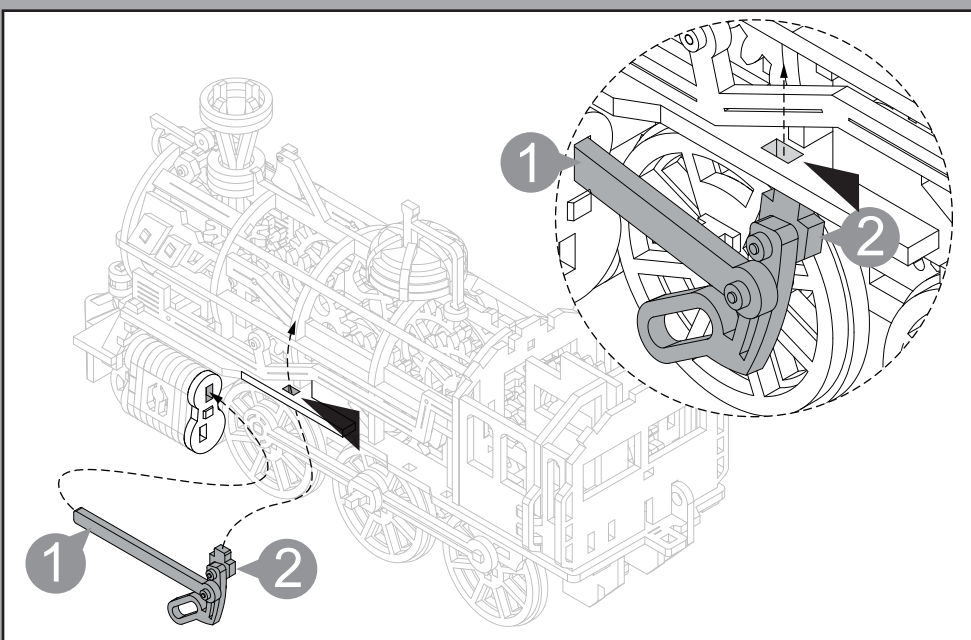

- F33
- F34
- F35
- F36
- F38

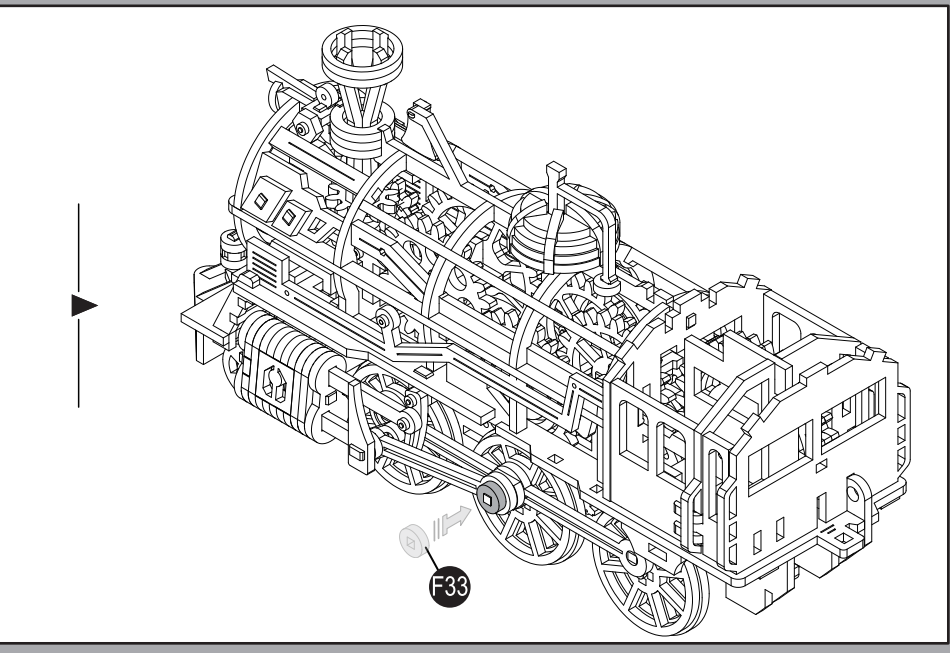
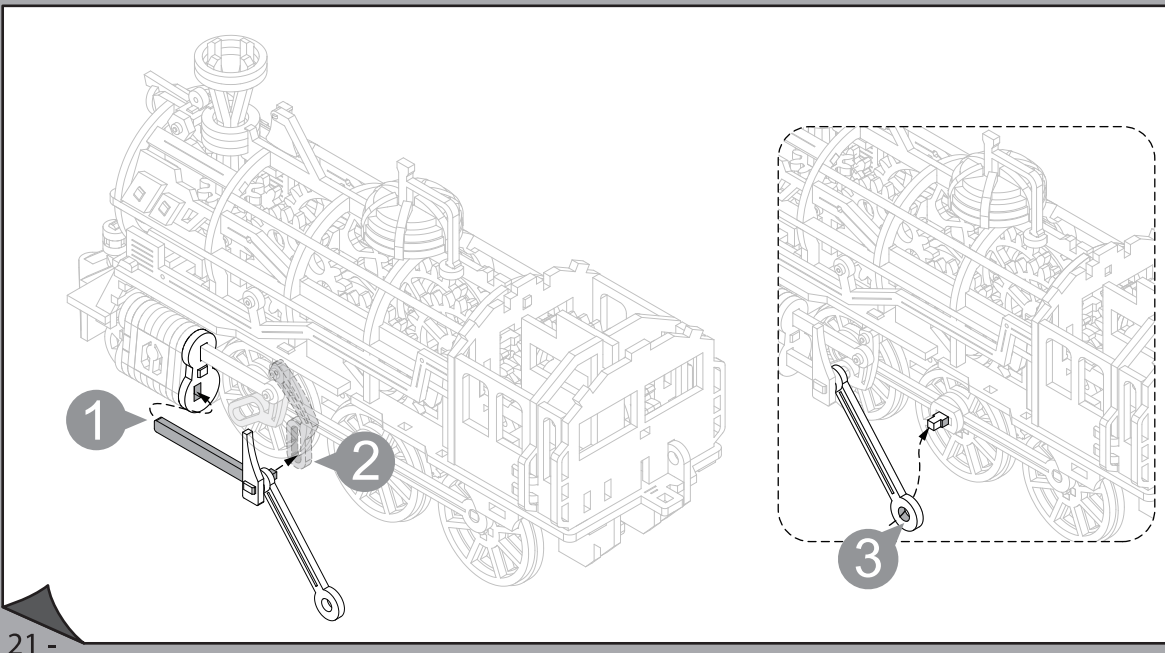
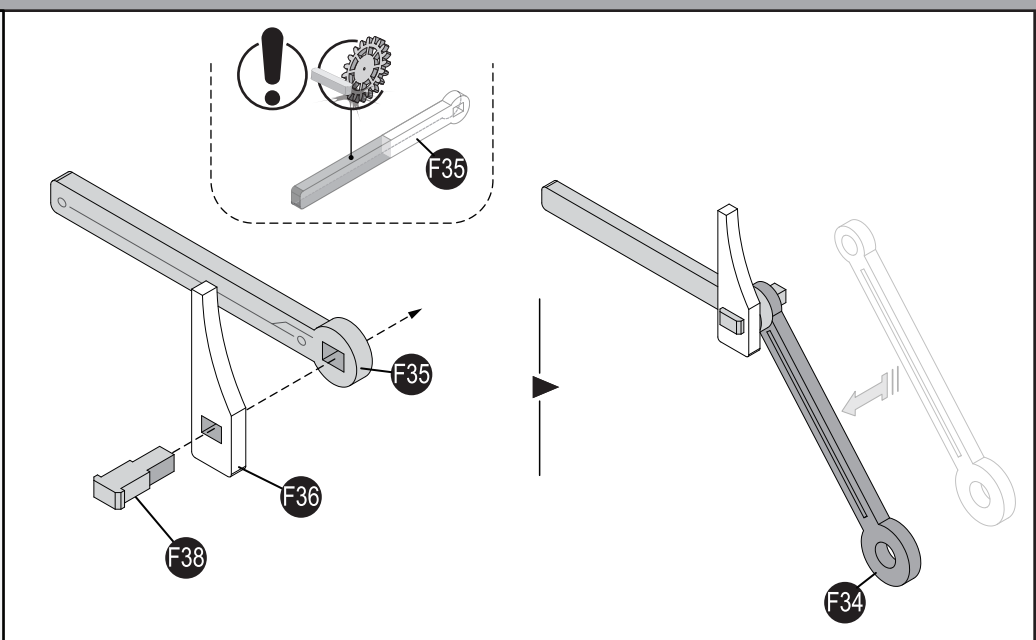

**28****27**P6 — **1:1**  
15mm

F29

F30

F31

P5 x4

P6 x2

F27

F28

F32

F33

F34

F35

F37

F38

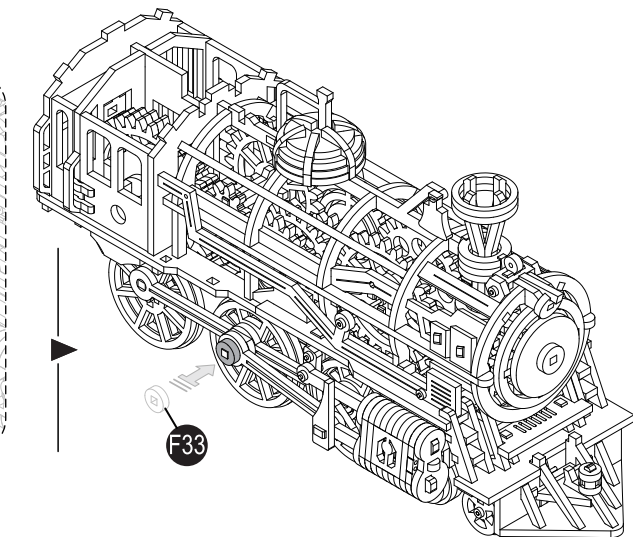
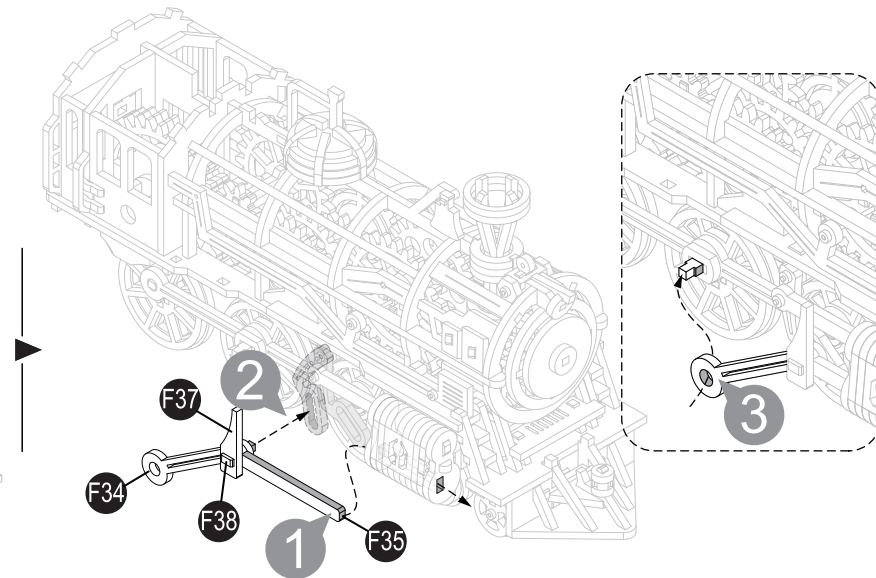
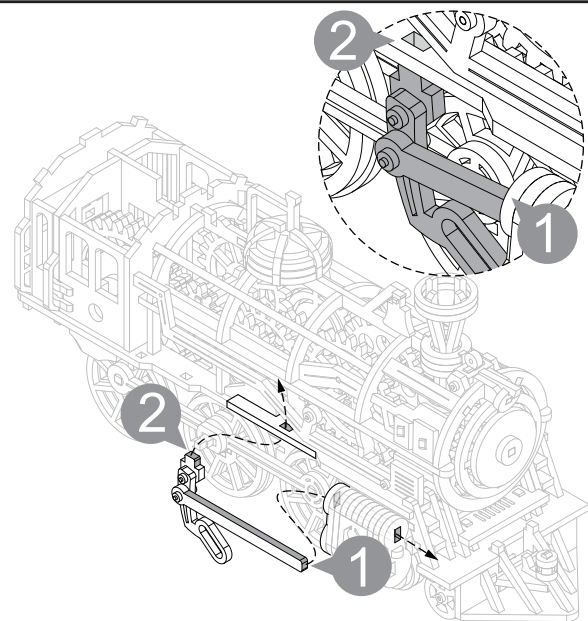
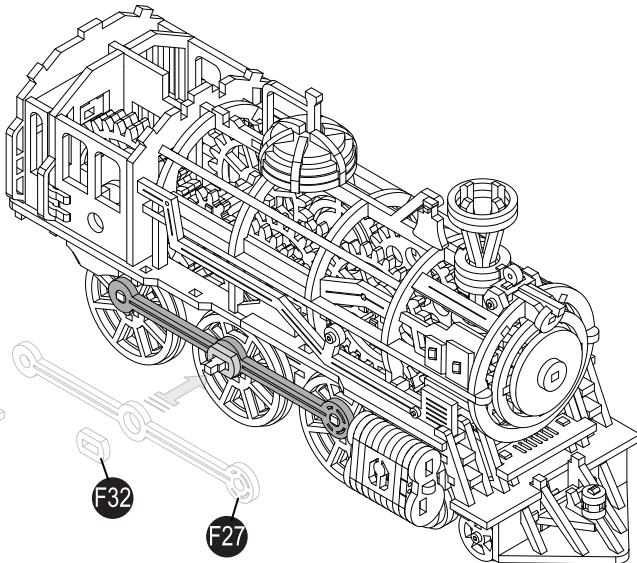
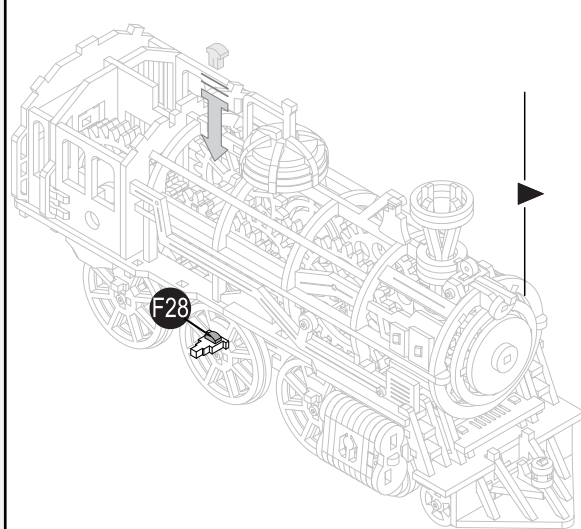

29

- F39
- F40
- F41 x2
- D4
- G1
- G2

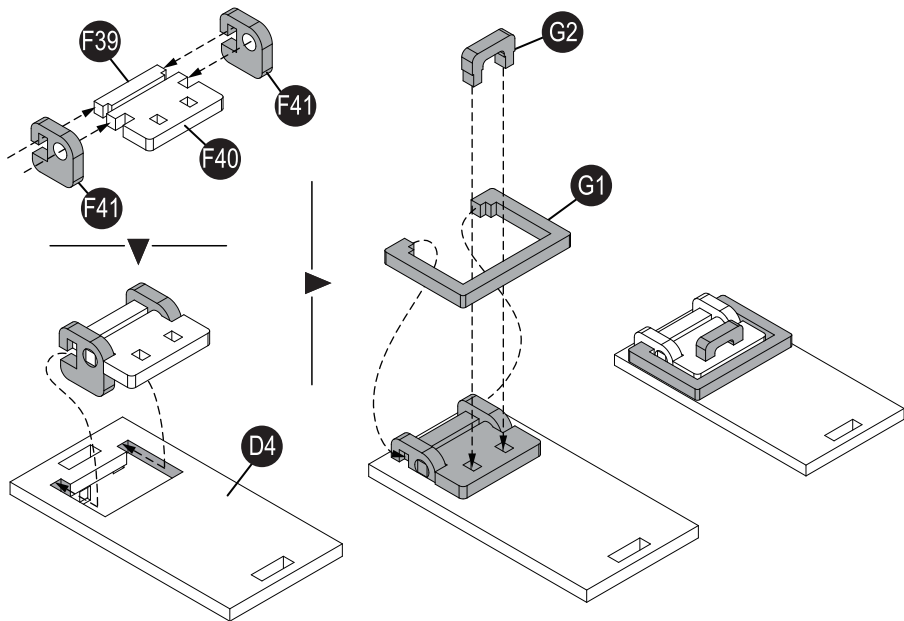

- G3
- G4
- G5
- G6
- G7 x2
- G8 x2
- G9

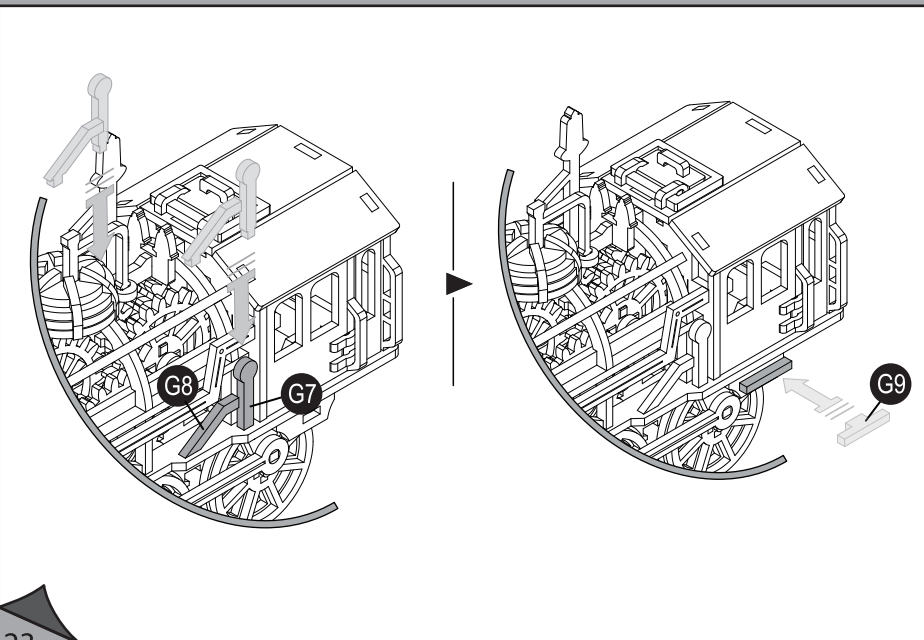
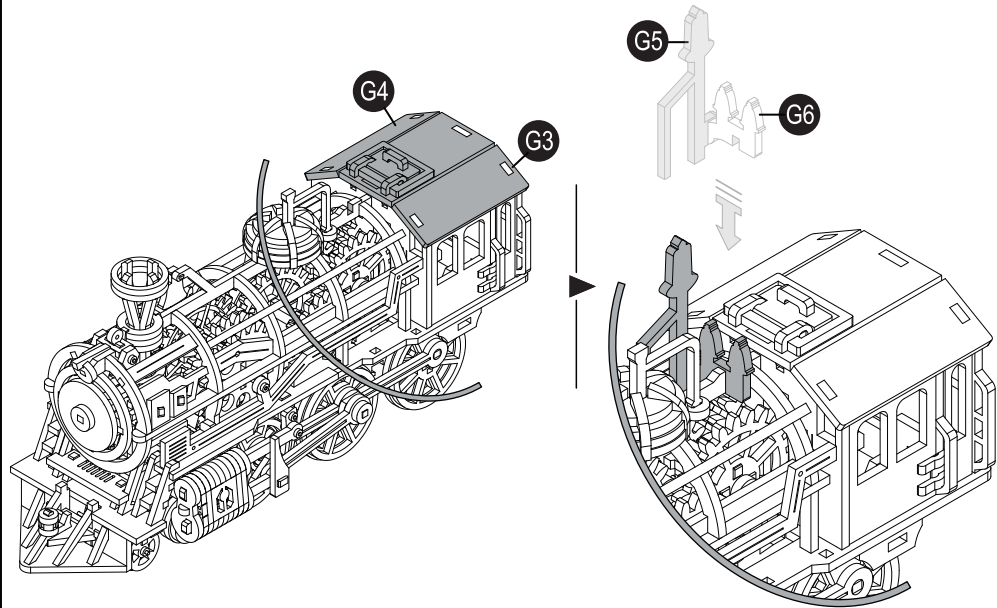

30

- G10 x2
- H2 x3

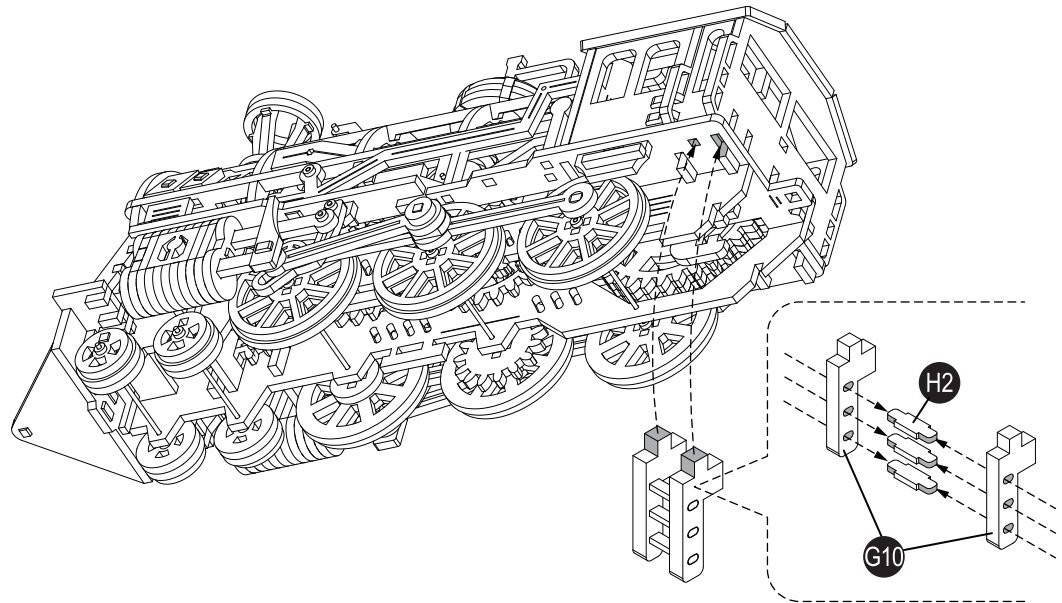



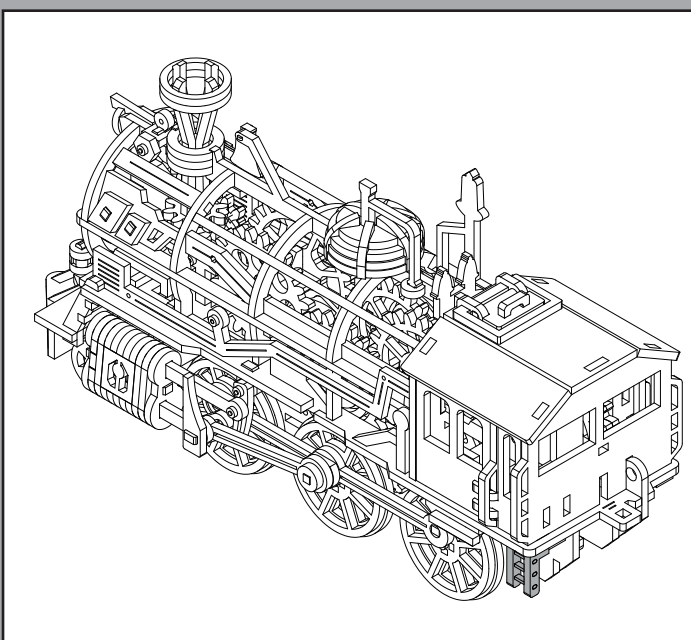

- 31**
- G11
  - G12
  - G13
  - G14
  - G15
  - G16

---

  - H3
  - H4

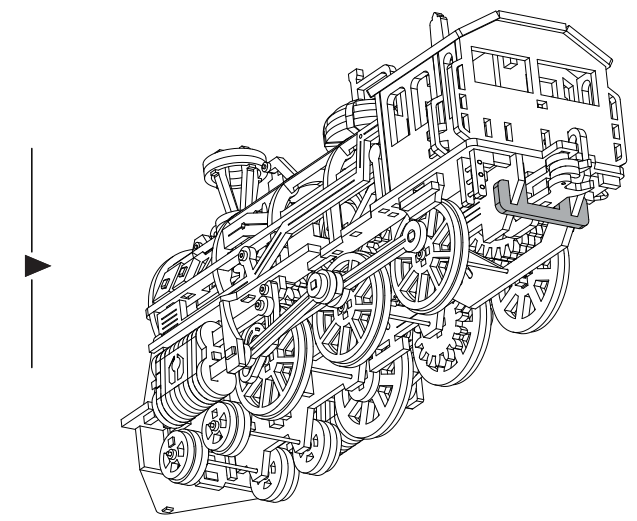
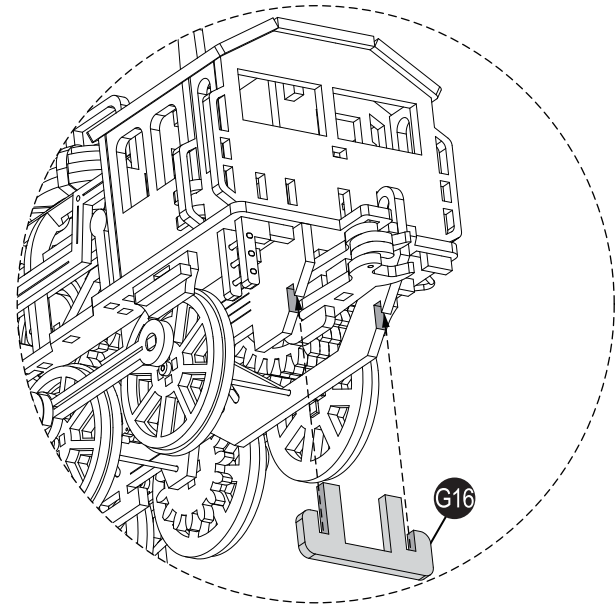
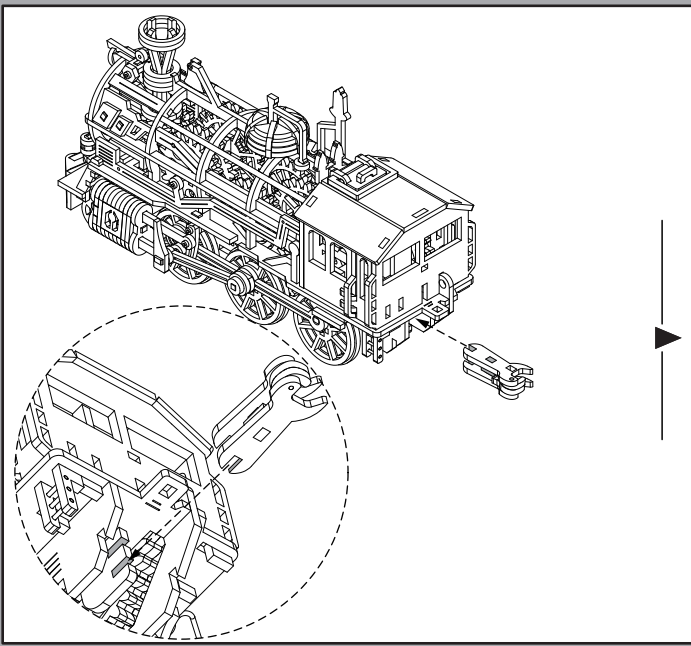
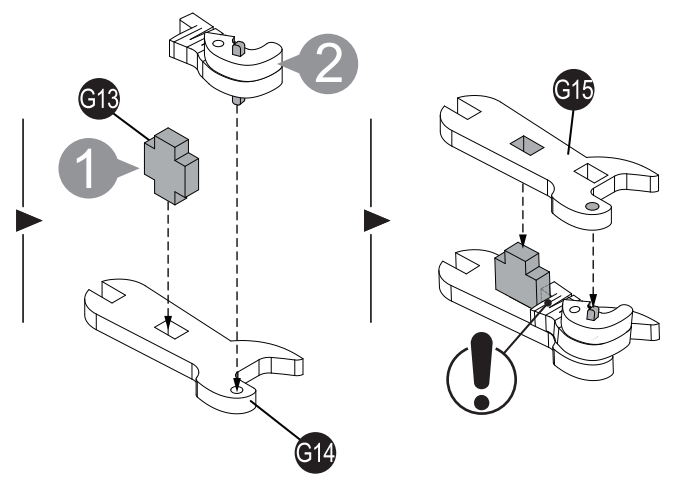
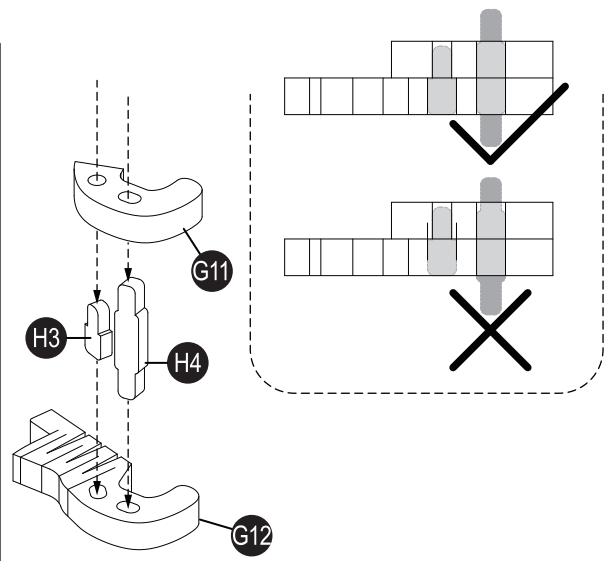

G17

G18x2

G19

G20

G21

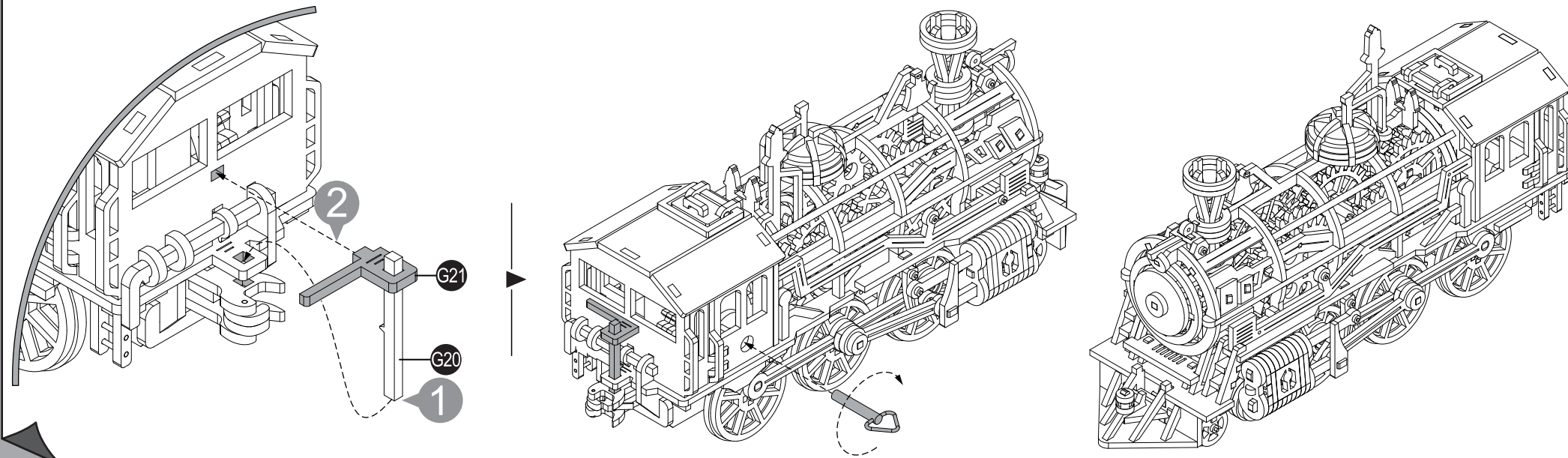
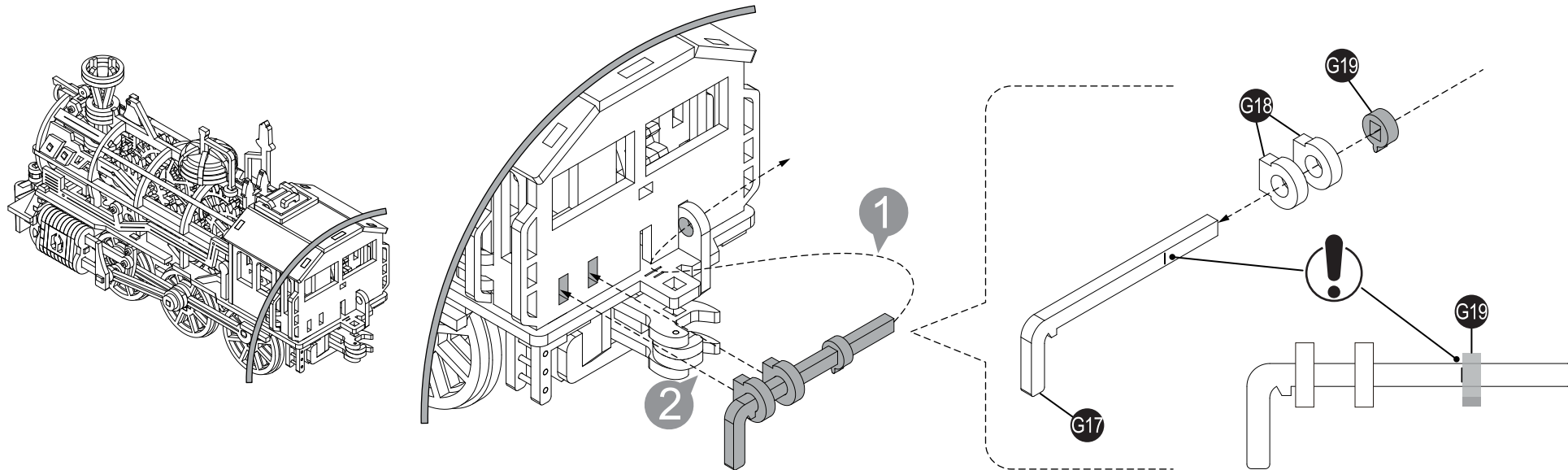

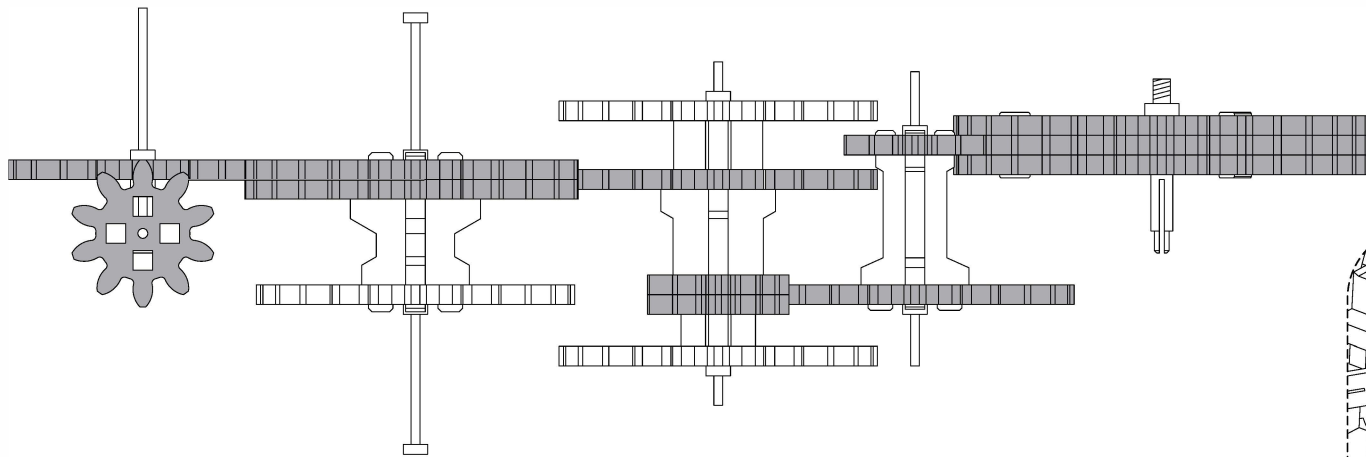

----- Sprawdź położenie kół zębatych -----

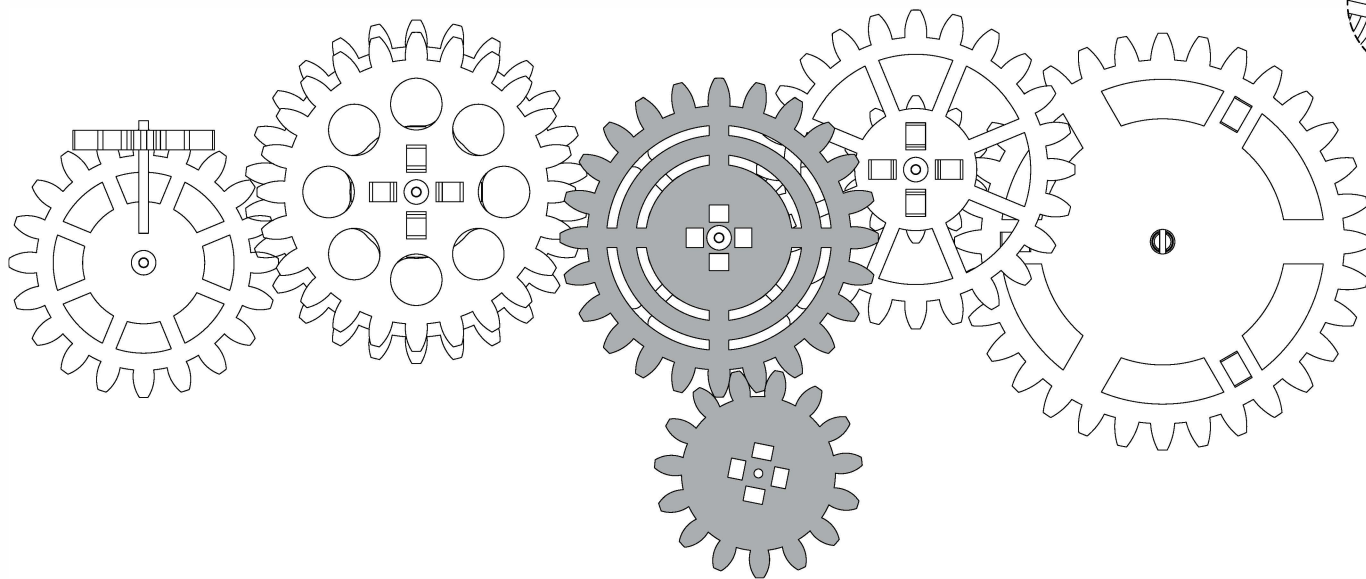
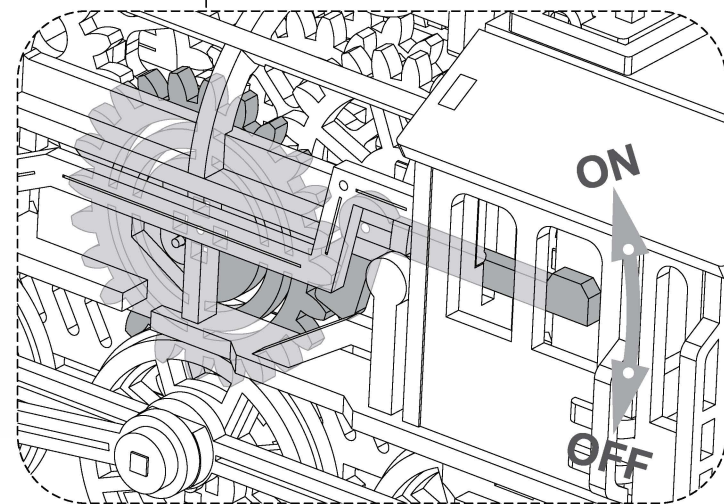

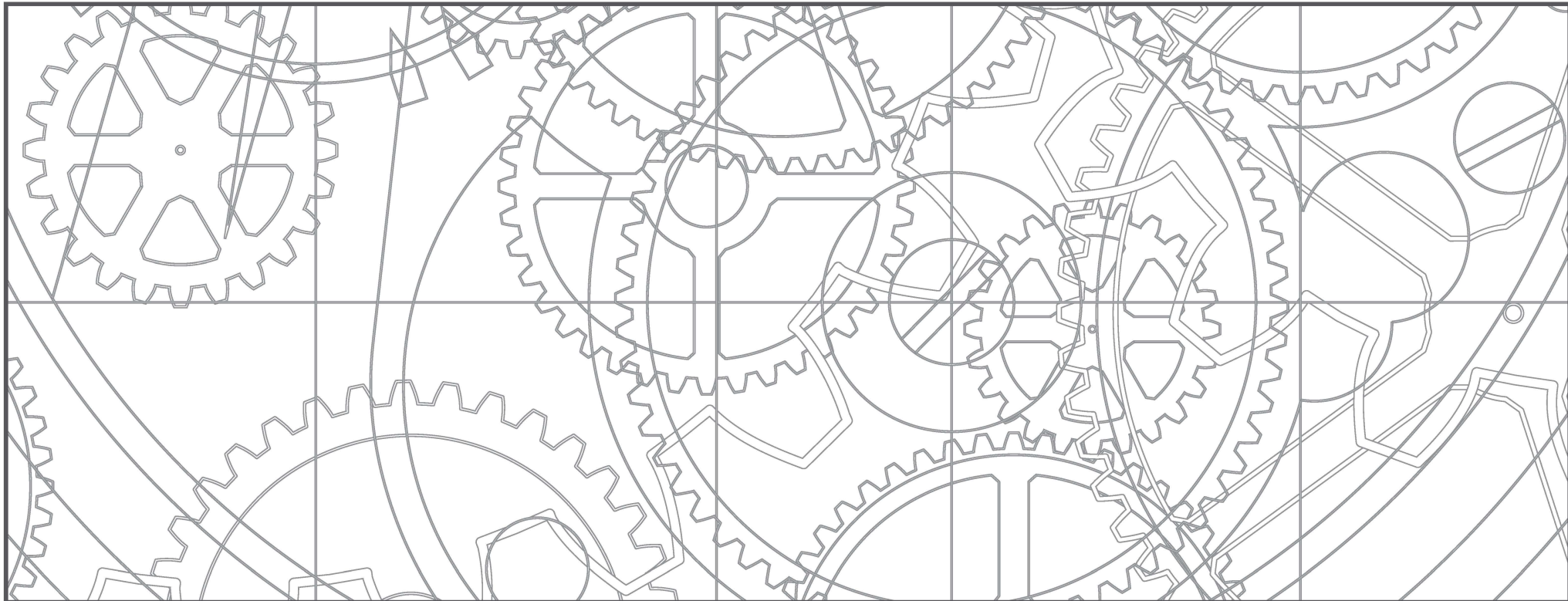

Znajdź nas na  
**[facebook.com/robotimepolska](https://facebook.com/robotimepolska)**  
lub odwiedź  
**[www.robotime.com.pl](http://www.robotime.com.pl)**