

ROKR[®] **TOR MECHANICZNY**

LG502-v1

DREWNIANE PUZZLE 3D

MODELE MECHANICZNE

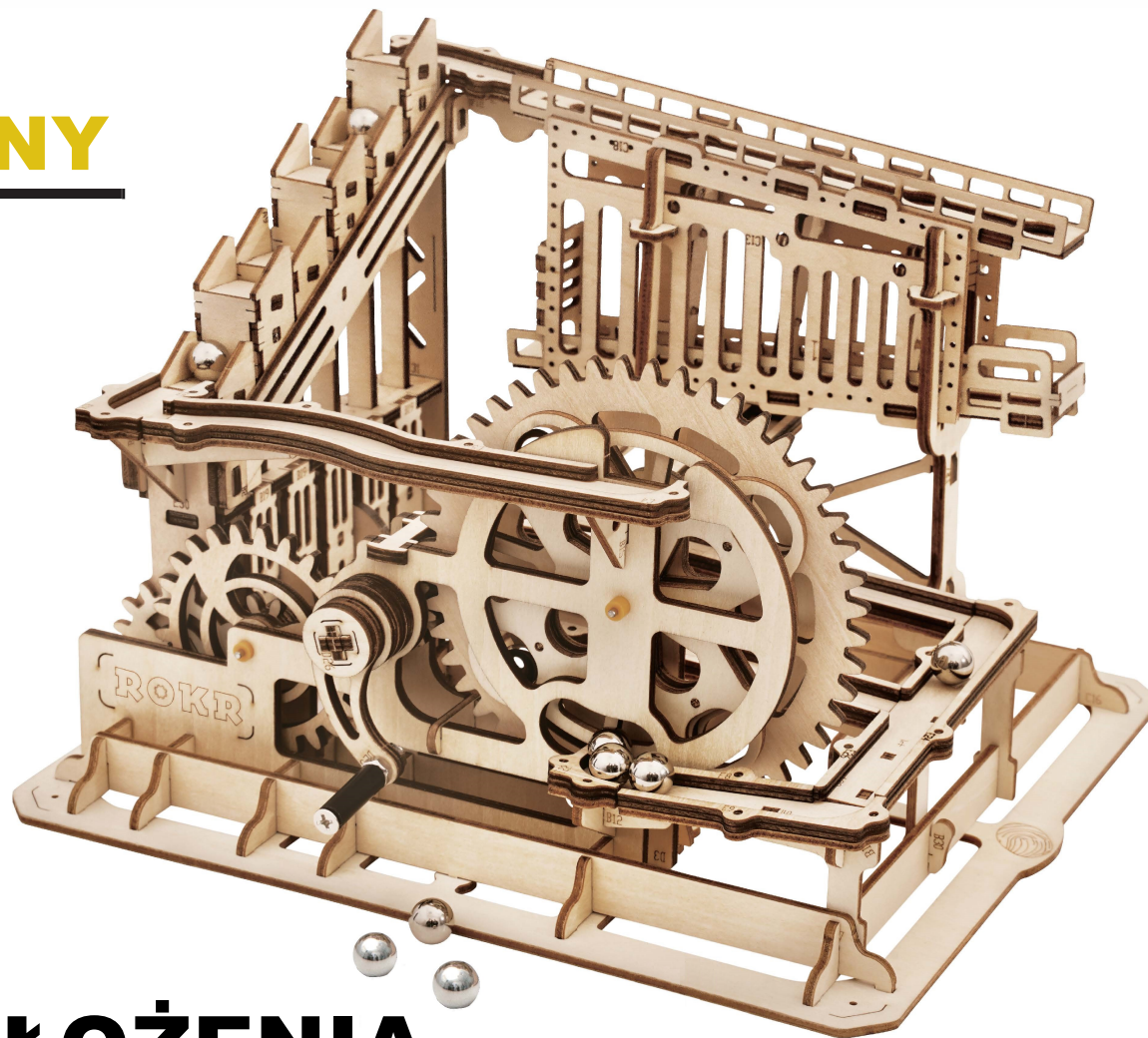

INSTRUKCJA ZŁOŻENIA

OSTRZEŻENIE

Zestaw zawiera małe elementy-ryzyko zadławienia.
Produkt przeznaczony dla osób powyżej **14 lat**.
Dzieci muszą składać pod nadzorem dorosłych.F

KONSERWACJA

- 1.Trzymaj produkt daleko od źródeł ognia.Nie zanurzaj w wodzie.
- 2.Nie używaj środków do czyszczenia zawierających alkohol lub amoniak.
- 3.Użyj czystej,miękkiej tkaniny aby wyczyścić produkt.



UWAGA

- Oddziel elementy od ramy zgodnie z każdym krokiem instrukcji przed montażem i umieść je prawidłowo.
- Dodatkowe elementy można wykorzystać jako części zamienne.
- W razie potrzeby wyszlifuj elementy papierem ściernym.
- W przypadku problemu z montażem zeskanuj kod QR,aby zobaczyć film instruktażowy.
- Proszę zachować instrukcję,gdyż zawiera ważne informacje.

Zeskanuj kod QR

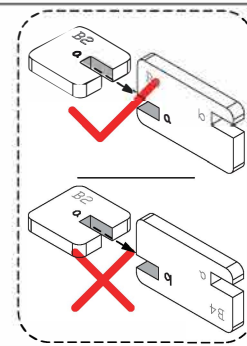

Podziel się z nami swoją opinią na temat produktu lub zaprezentuj swój model na :

[facebook.com/robotimepolska](https://www.facebook.com/robotimepolska)

Sprawdź również zawsze aktualną ofertę oraz nasze nowości na :

www.robotime.com.pl



Chętnie odpowiemy na wszystkie pytania.



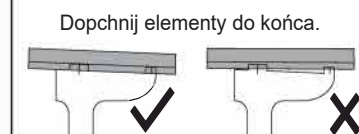
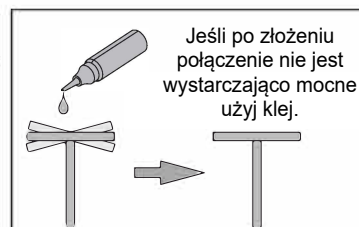

PROBLEM	PRZYCZYNA	ROZWIĄZANIE
Tor nie pracuje płynnie.	1.Tarcie między elementami jest za duże. 2.Łączenia nie są gładkie.	1.Nasmaruj elementy. 2.Wypoleruj punkty połączeń papierem ściernym i upewnij się, że każda część jest dobrze zmontowana.
Kulki blokują się na torze.	1.Gniazdo nie jest połączone do końca. 2.Tor nie jest odpowiednio nachylony.	1.Dociśnij gniazdo,aby prawidłowo połączyć je z końcem. 2.Sprawdź, czy tor jest odpowiednio połączony ze sobą i upewnij się, że wszystkie części są dobrze zmontowane.

Rady:



Lista elementów:

Element	Rękaw drążka	Stalowy drążek	Kolumna izolacyjna
Numer	P1	P2	P3
Ilustracja			
Ilość	10	3	1

Element	Śruba	Nakrętka	Stalowa kulka	Wosk
Numer	P4	P5	P6	P7
Ilustracja				
Ilość	1	2	10	1



Upewnij się, że części są odpowiednio dopasowane.



Zamontuj części symetrycznie.



Wyszlifuj elementy papierem ściernym.



Potrzebny wosk lub smar.



Upewnij się, że części obracają się swobodnie.



Krok 1



Krok 2



Zmiana perspektywy. Obróć zgodnie z kierunkiem strzałki na zdjęciu.



Zwróć uwagę podczas montażu.



Wykonaj 2 sztuki.

Narzędzia montażowe:

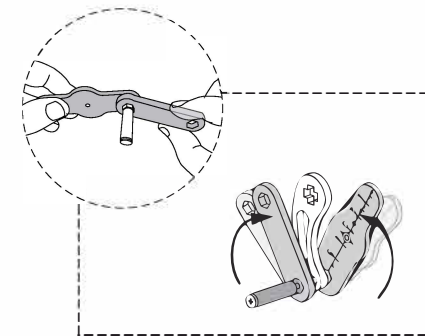
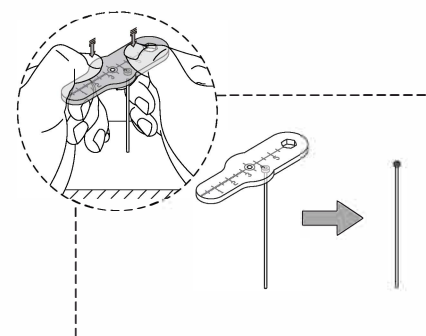
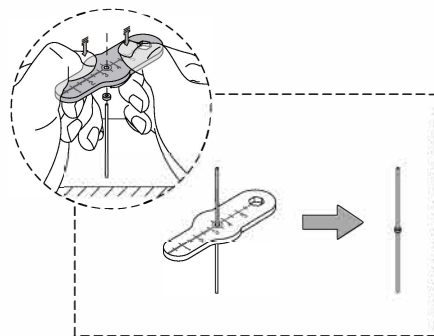
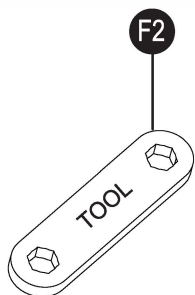
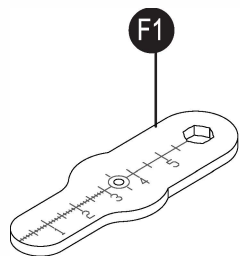

1

- B1
- C5 x2
- C6 x2
- C7 x2
- C8
- C9
- C12
- C17

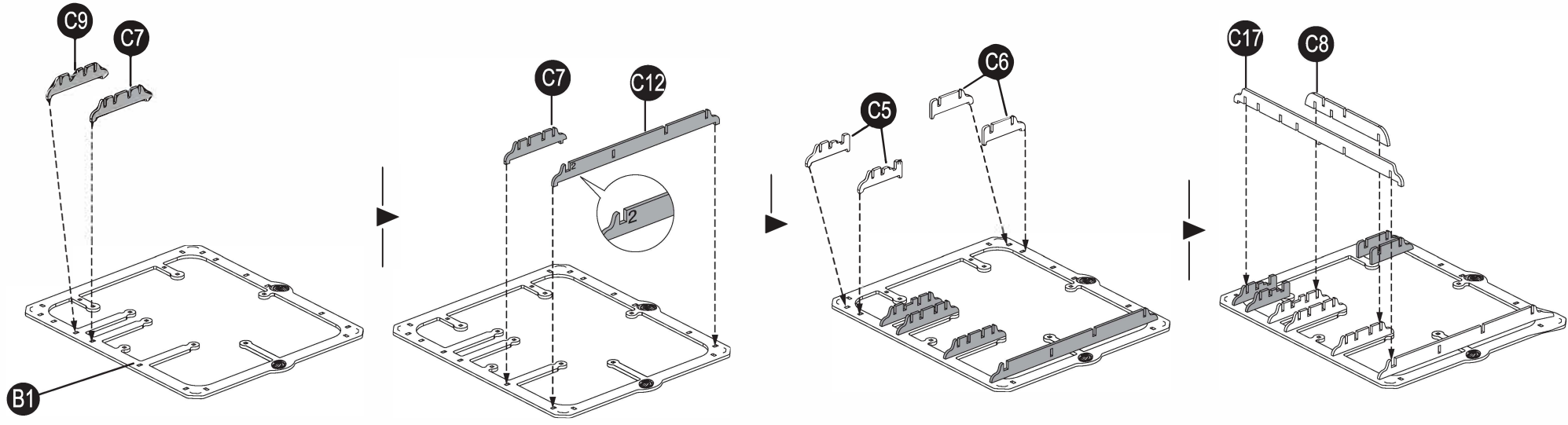

- C10
- C11
- C13
- C14
- C15
- C16

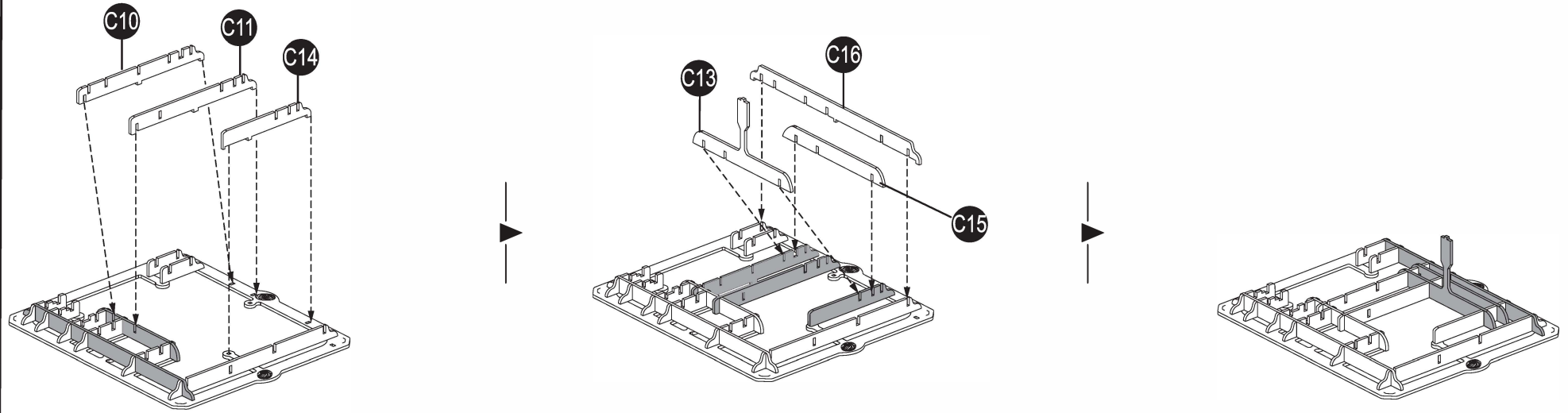

2

A1

B7

F1

G2 x4

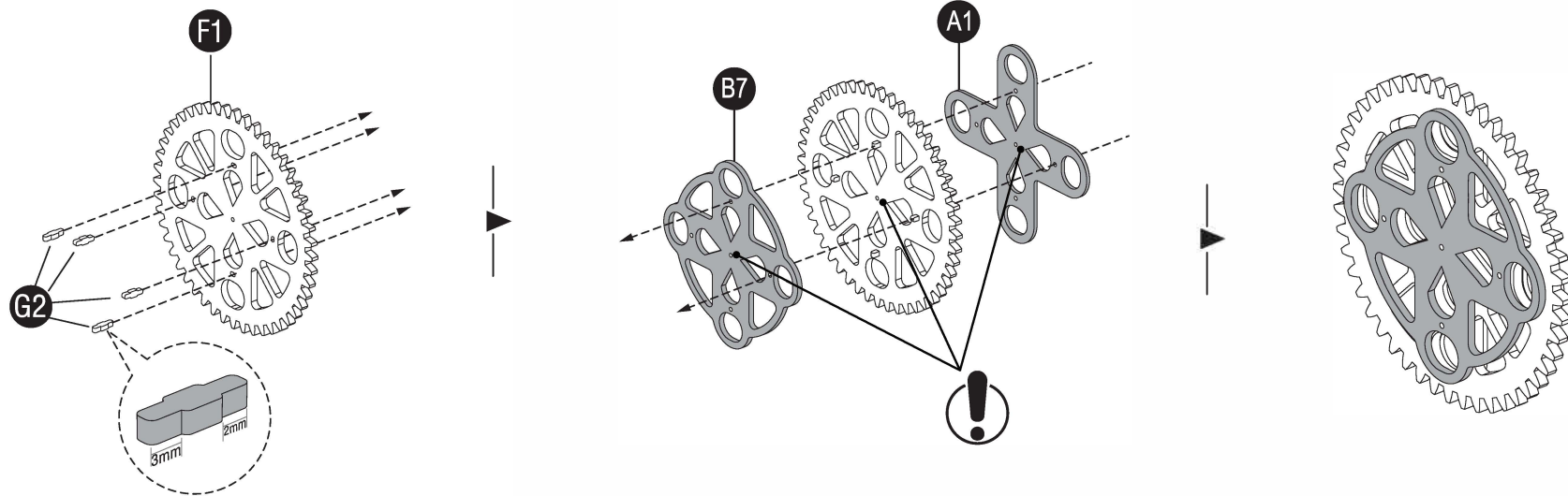

3

E1

E3

G3 x3

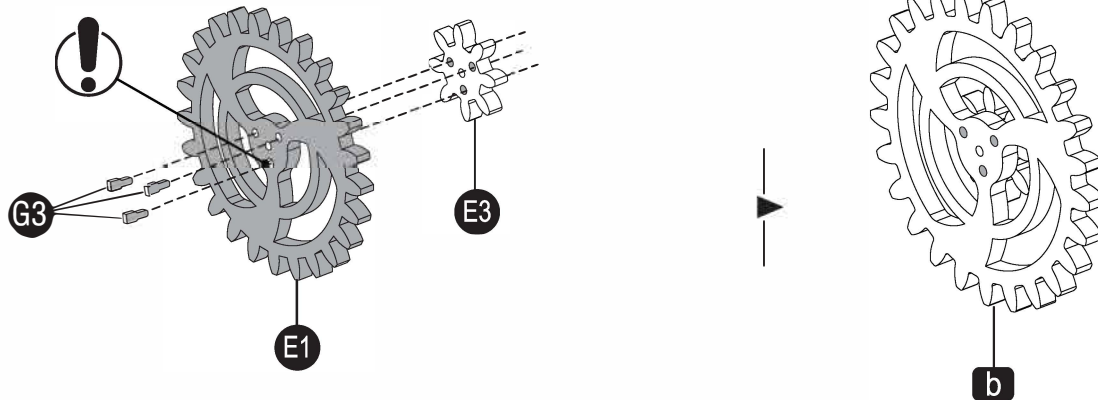
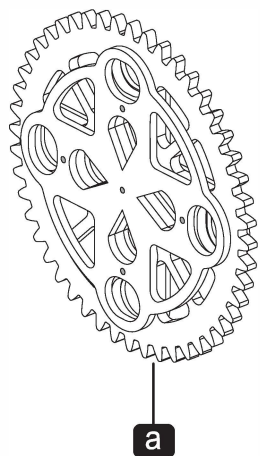

b

4

- A2
- A3
- A4
- A5
- D1
- D2
- D3
- D14
- D15
- D16
- D24
- E2 x2

- P1 x7
- P2 x2
- P7

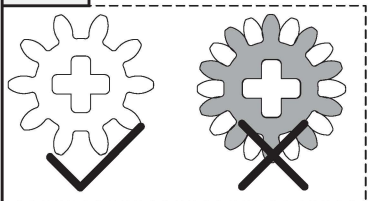

P1 x4  P2 x2  30mm  1:1

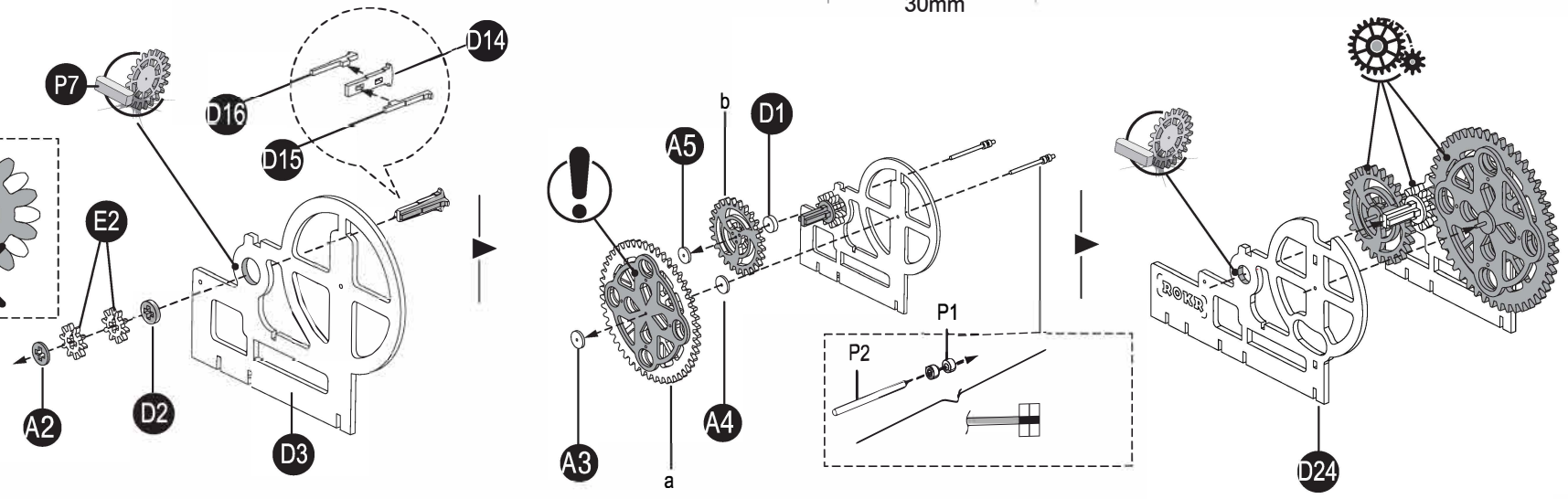

- B17
- D13

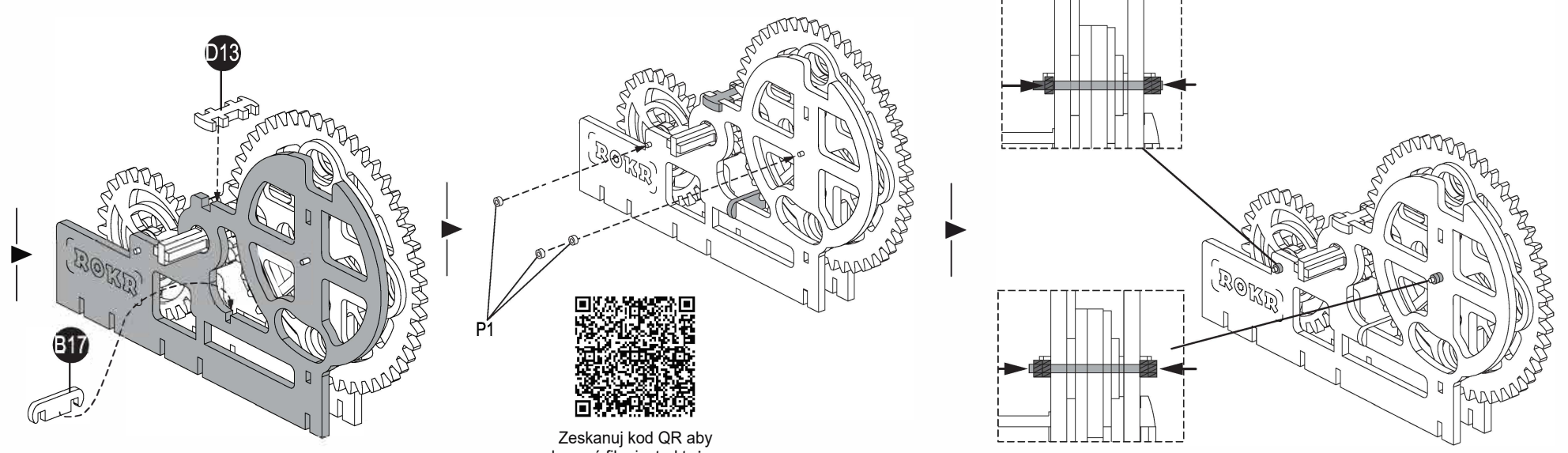

Zeskanuj kod QR aby zobaczyć film instruktażowy.

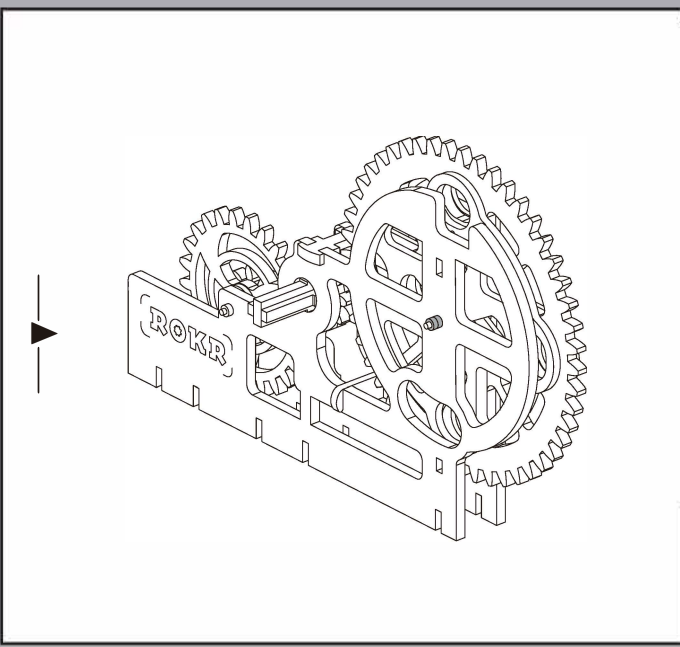

- 5**
- D25
 - D26
 - D27 x3
 - P3
 - P4
 - P5 x2
 - F4
 - F5

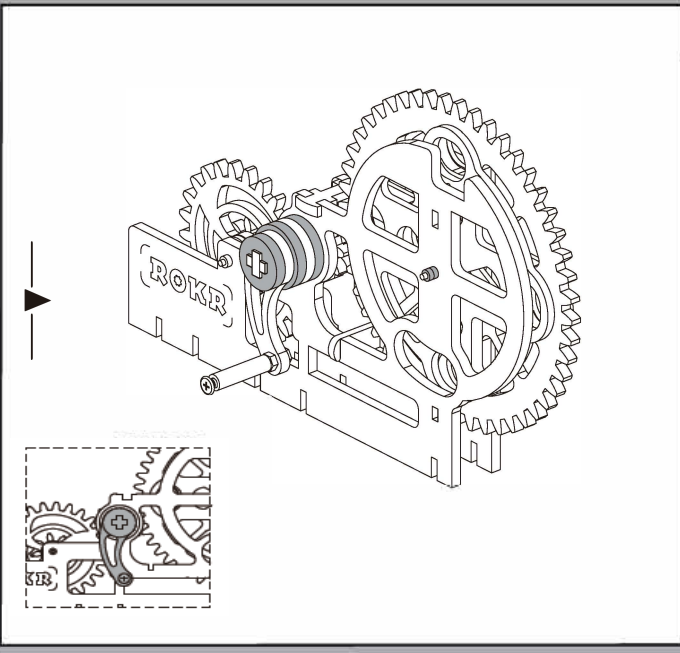
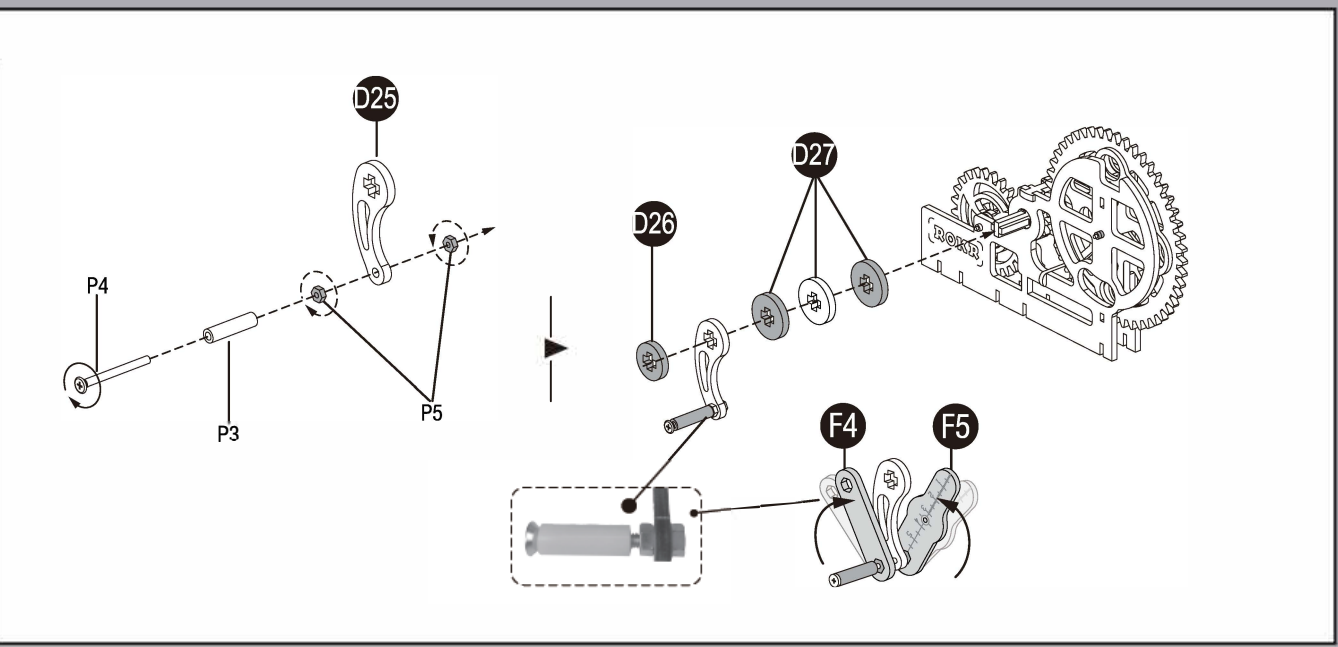

- 6**
- B11
 - B12
 - B15

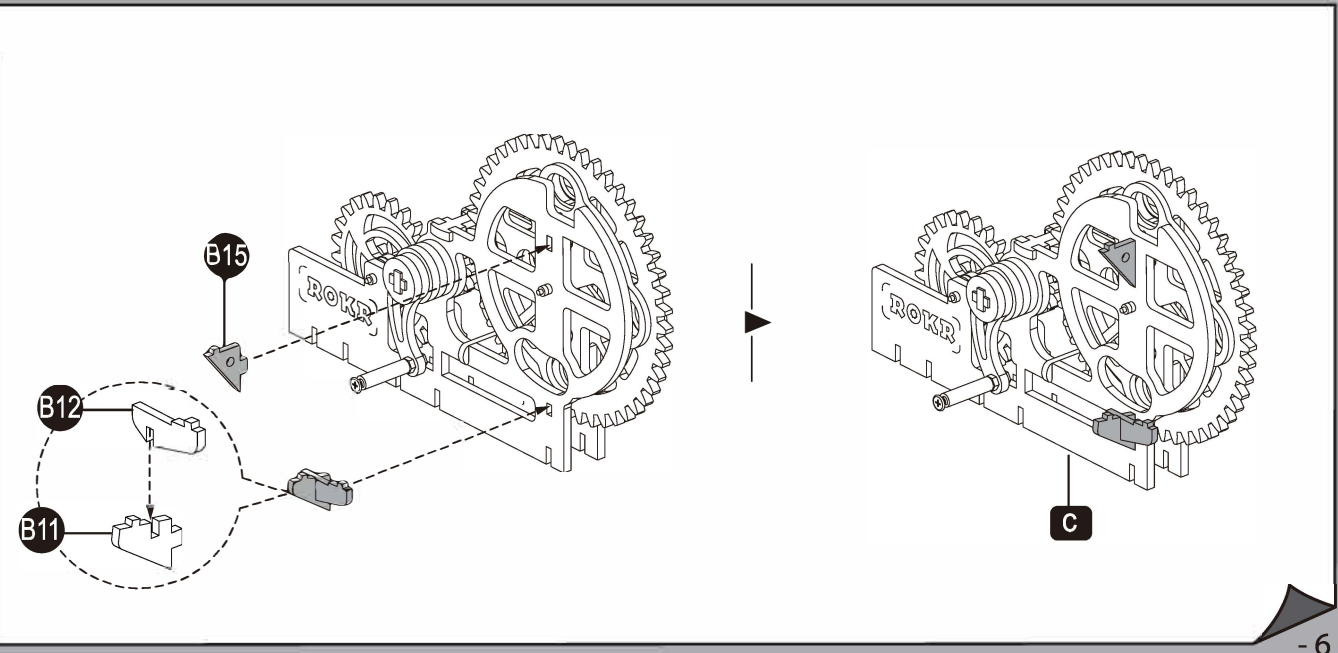

7

D19x2
D20

G4 x2

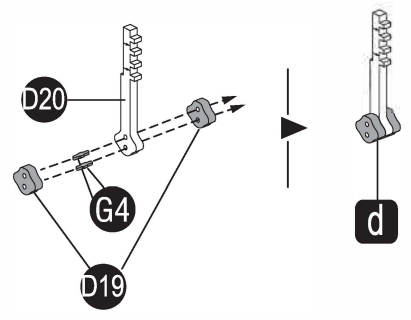

d

8

D19x2
D21

G4 x2

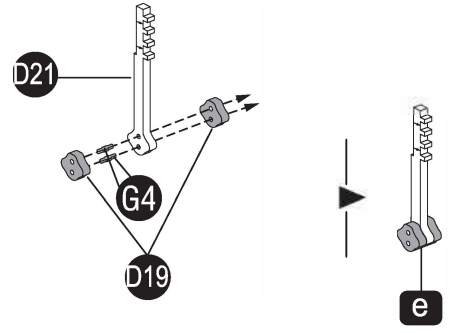

e

9

D9
D19x2

G4 x2

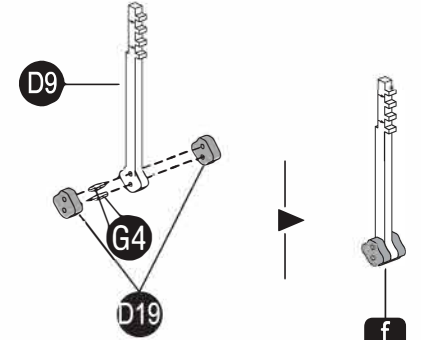

f

10

D8
D19x2

G4 x2

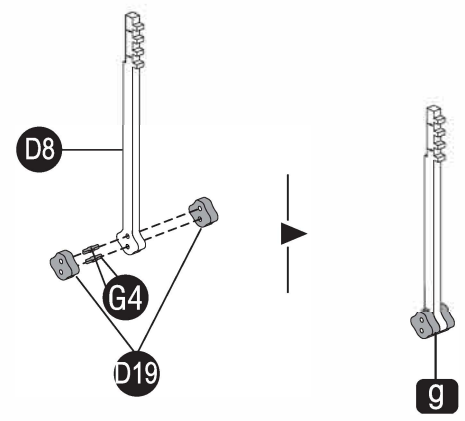

g

11

D7
D19x2

G4 x2

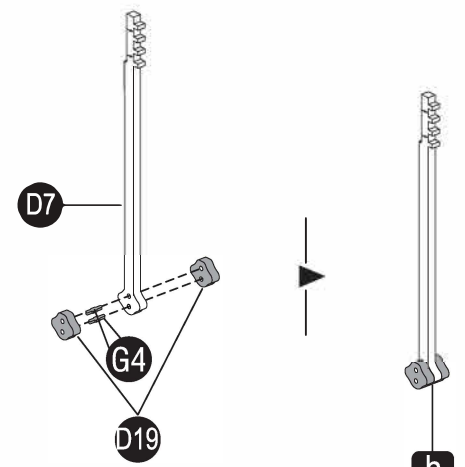

h

12

D6
D19x2

G4 x2

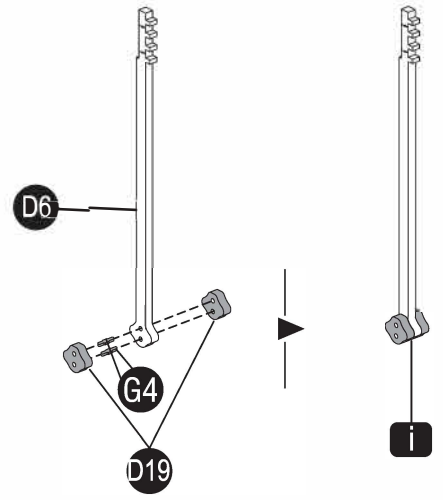

i

13

A6 x2

A7

A8

D4

D11 x2

D22

E36

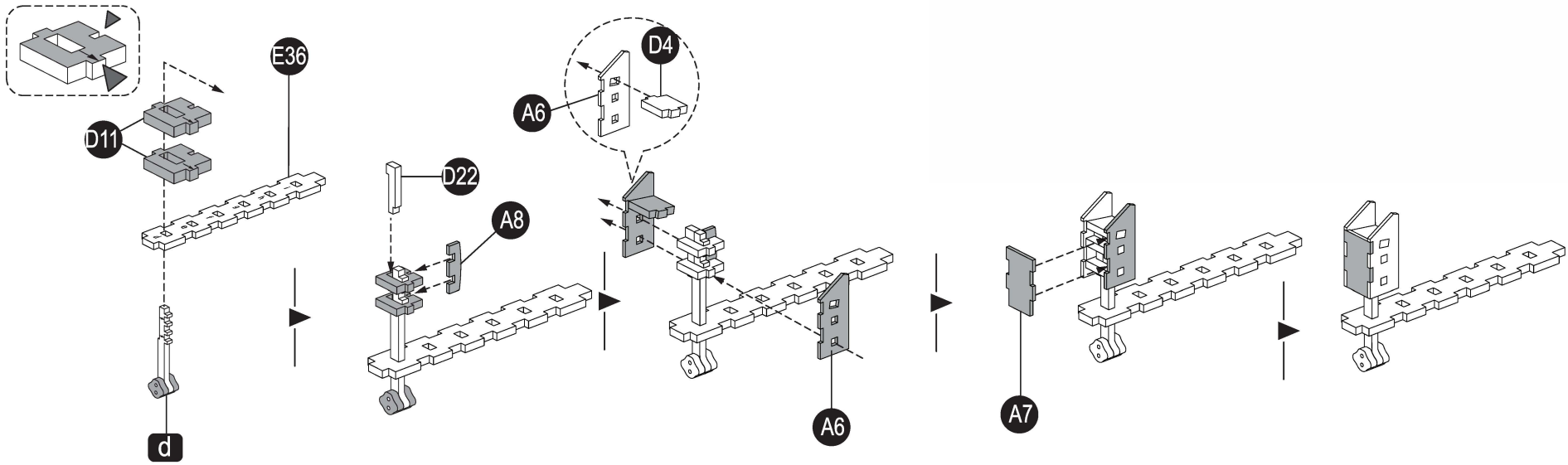
**14**

A6 x2

A7

A8

D4

D11 x2

D22

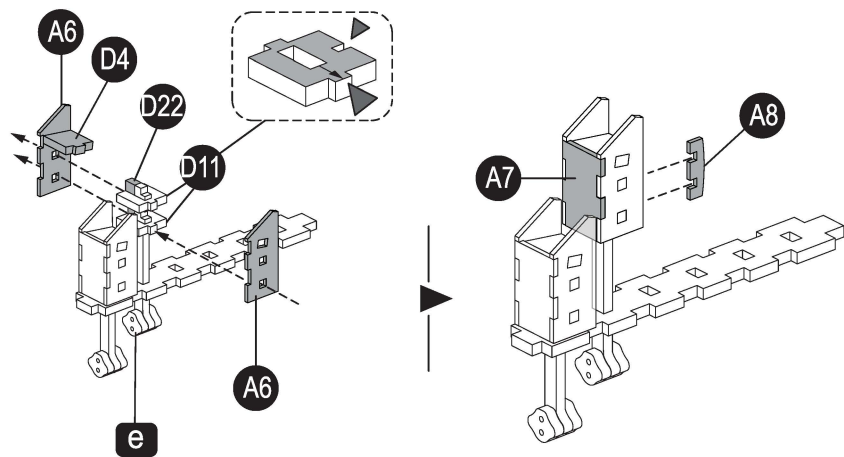
**15**

A7

A9 x2

D5

D12 x2

D22

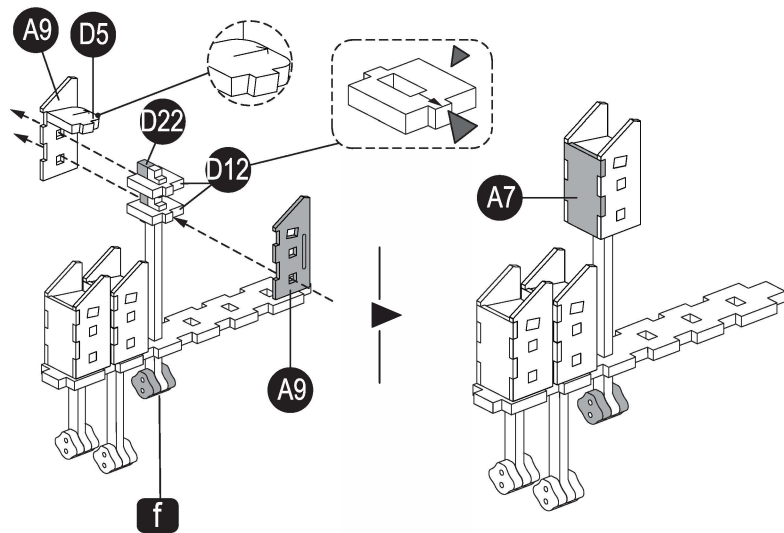

16

A6 x2

A7

A8

D4

D11 x2

D22

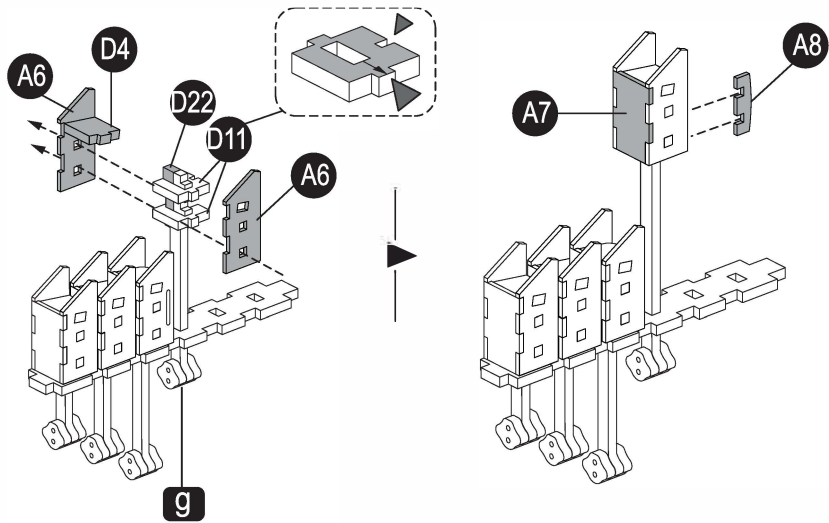

17

A6 x2

A7

A8

D4

D11 x2

D22

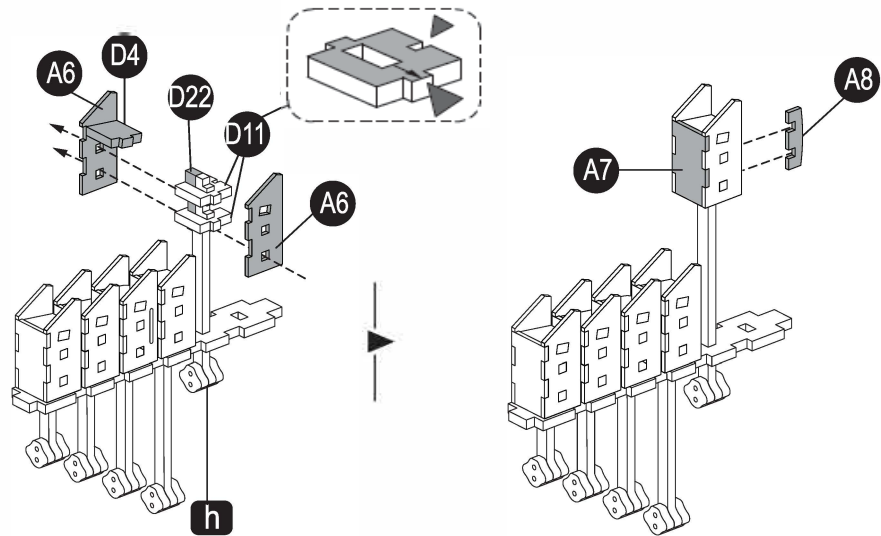

18

A6 x2

A7

D4

D10 x2

D22

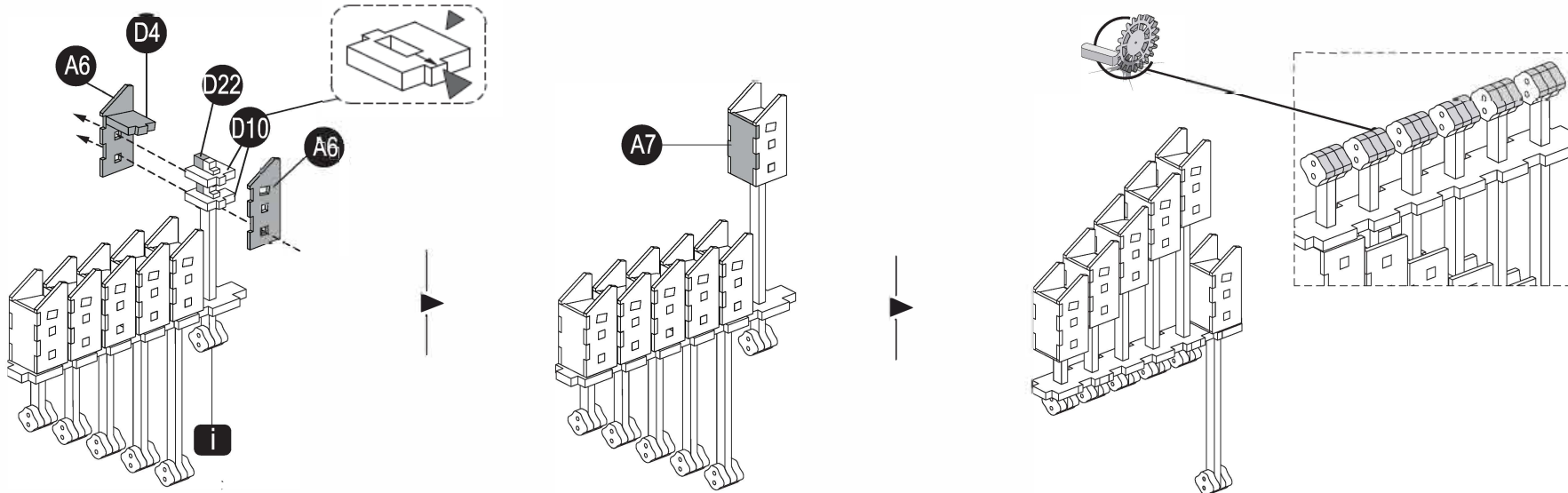

19

E32

E33

E34

F2 x6

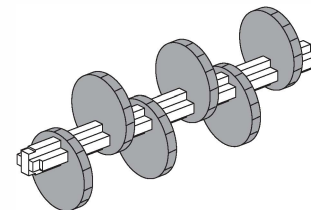
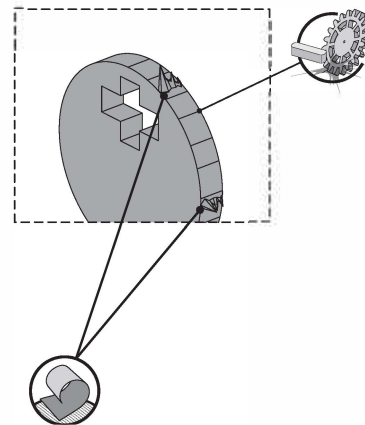
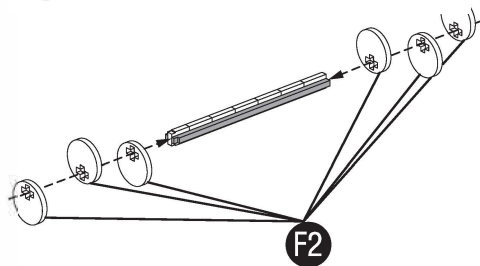
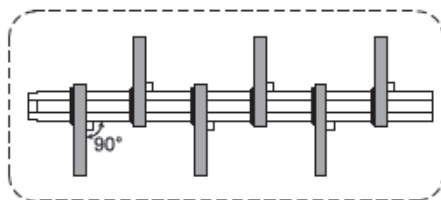
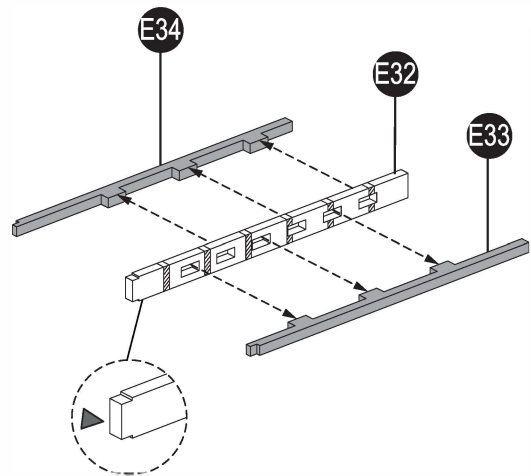

20

B2

E30

E35

E31

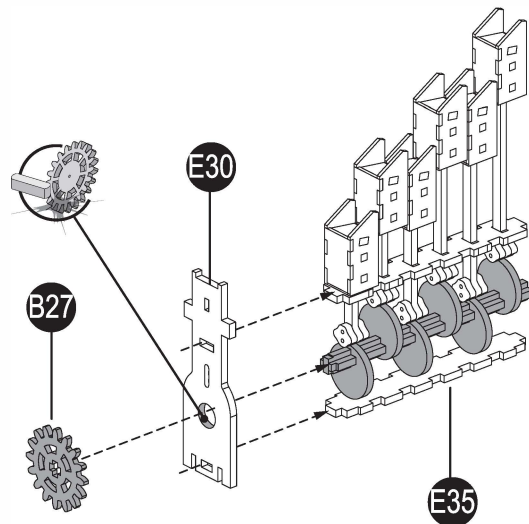

Zeskanuj kod QR aby
zobaczyć film
instrukżowy.

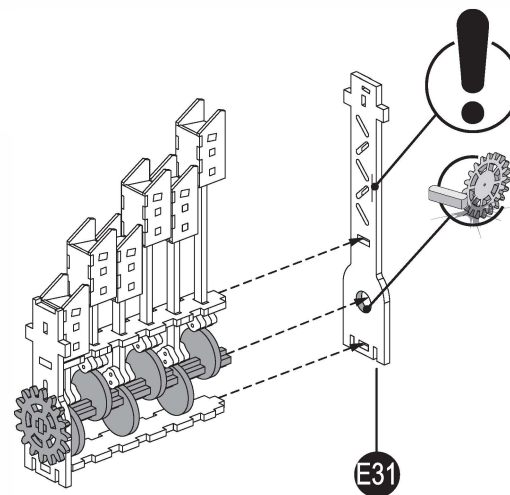

21

A10

B2 x2

B3 x2

B6 x2

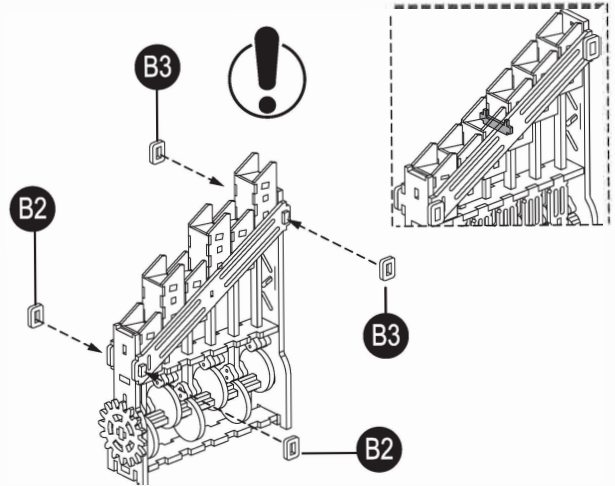
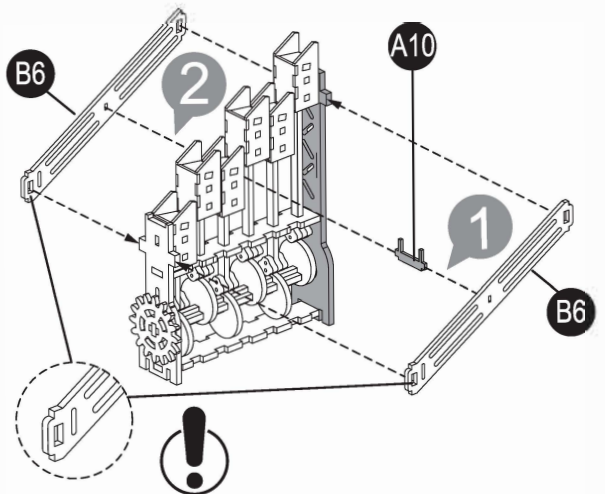

C18x5

B19x10

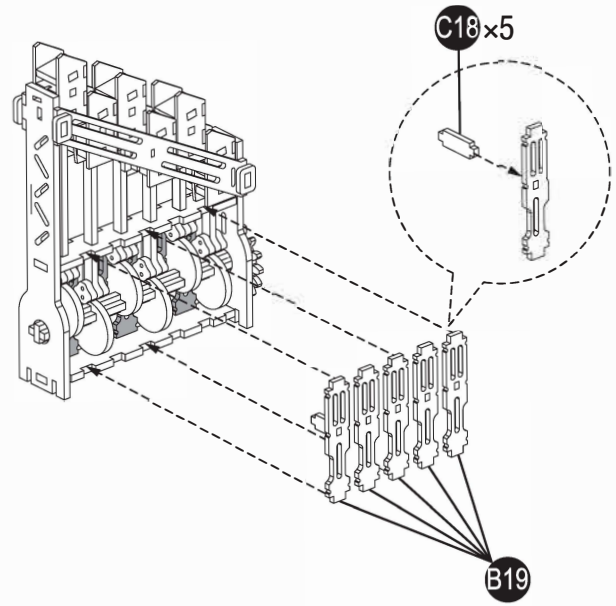
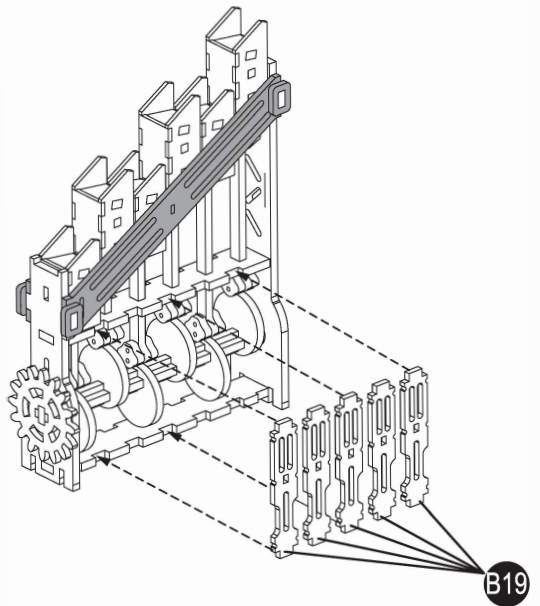

22

B8

B9

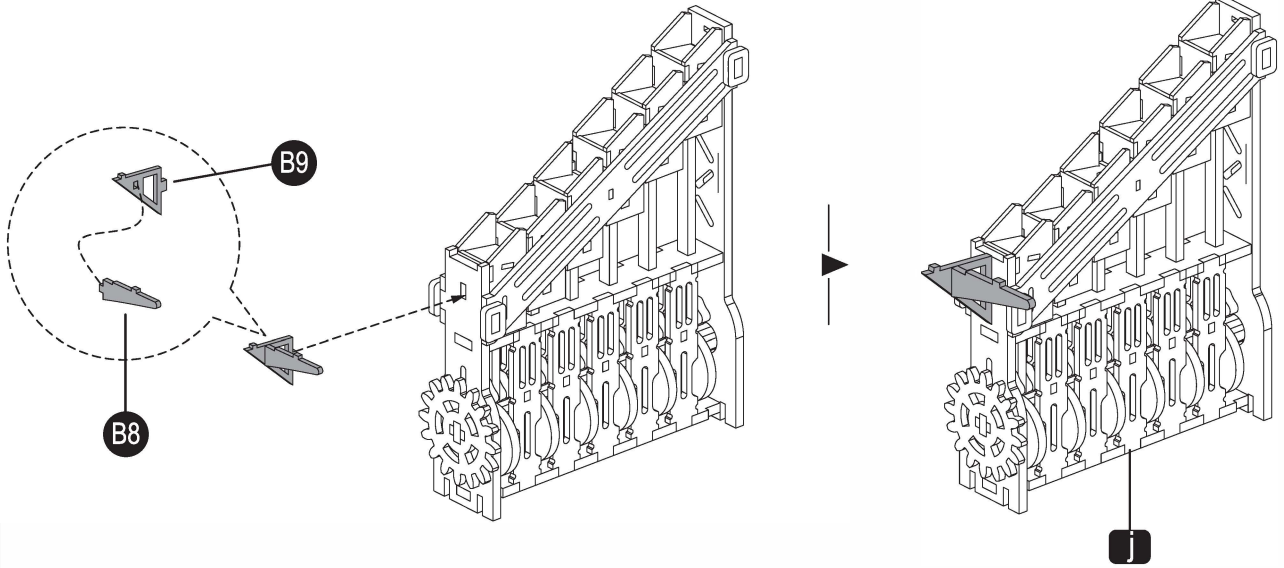
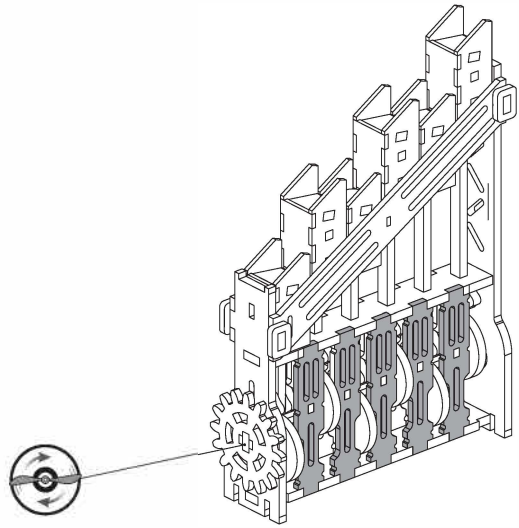

23

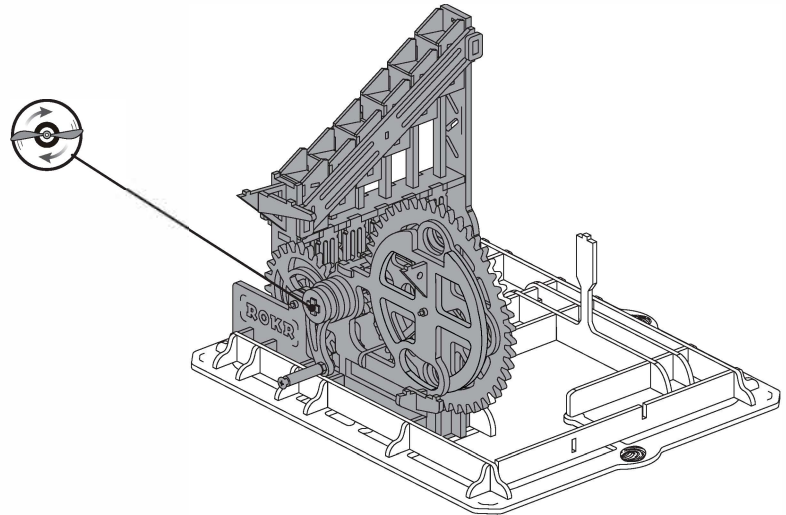
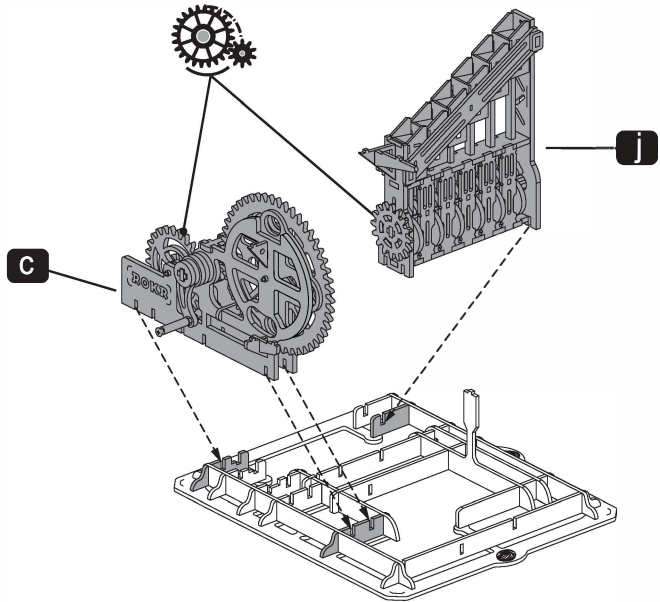

24

A11

E4

E5

G5 x4

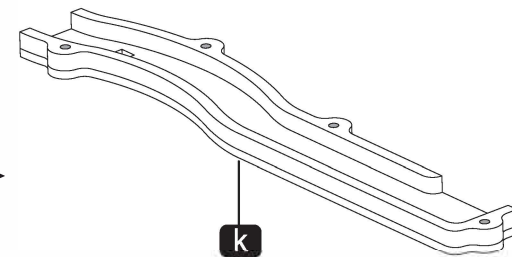
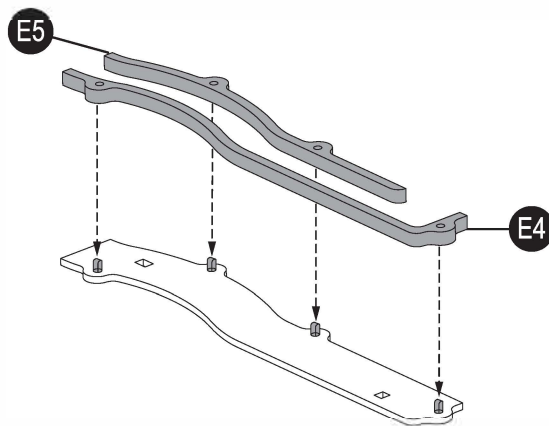
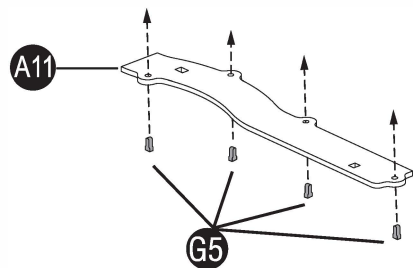

Zeskanuj kod QR aby
zobaczyć film
instruktażowy.

**25**

A12

E14

E15

G5 x3

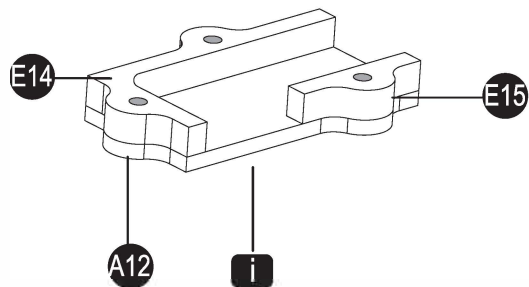
**26**

A13

B16

E12

E13

G5 x3

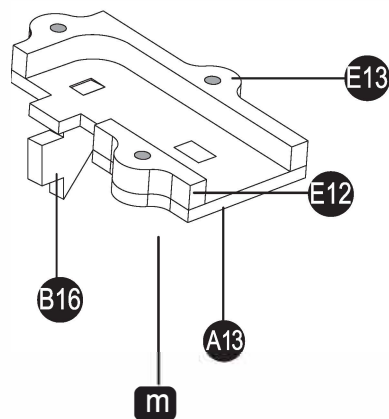
**27**

A14

B4

B5 x2

E10

E11

G5 x2

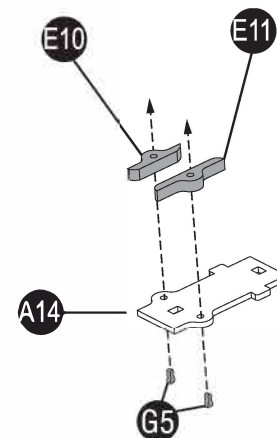

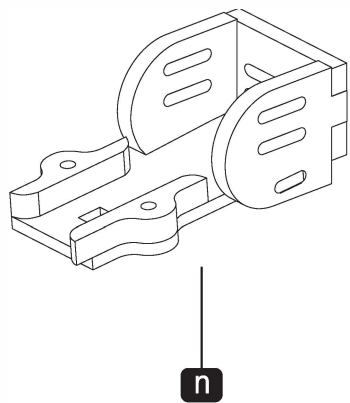
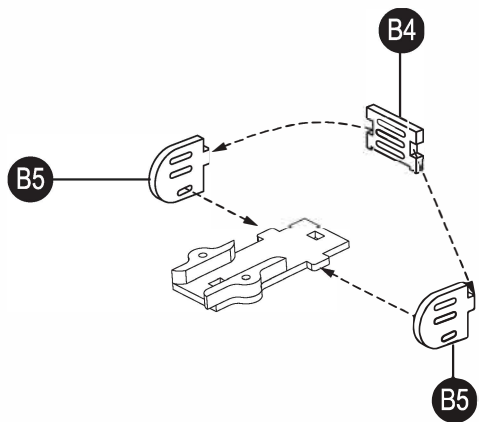

28

A15

E16

E17

G5x4

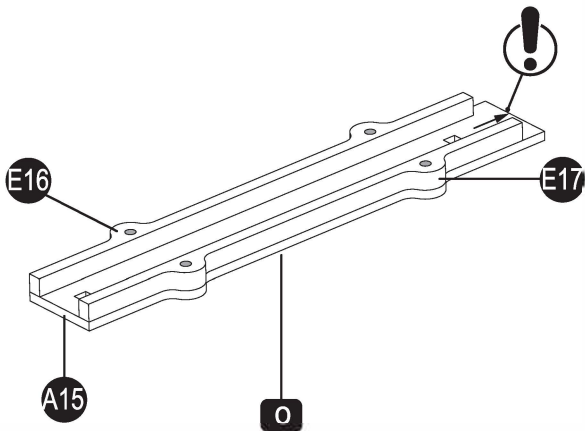

29

A16

E6

E7

G5x3

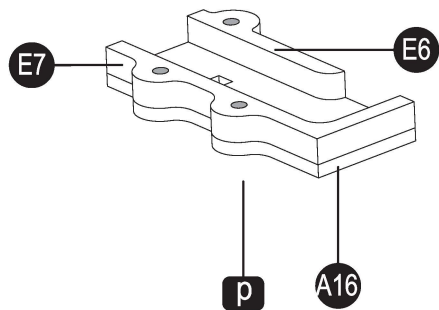

30

A17

E18

E19

G5x4

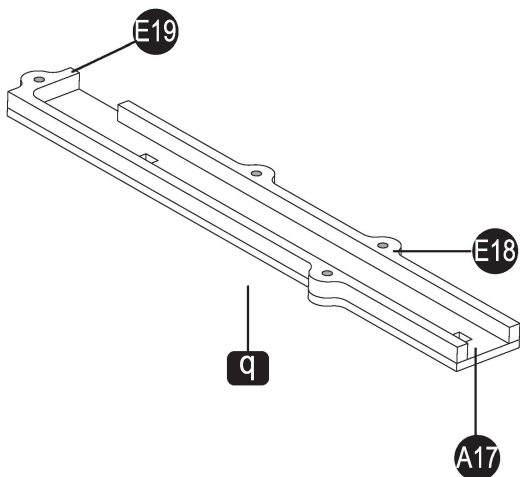

31

A29

E22

G5x2

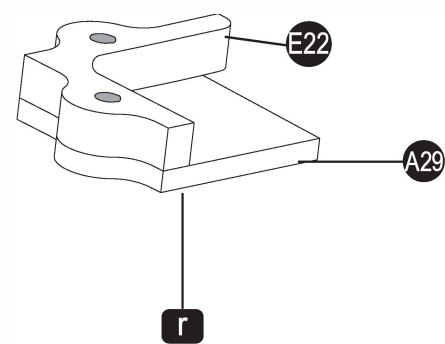

32

A20

E8

E9

G5 x3

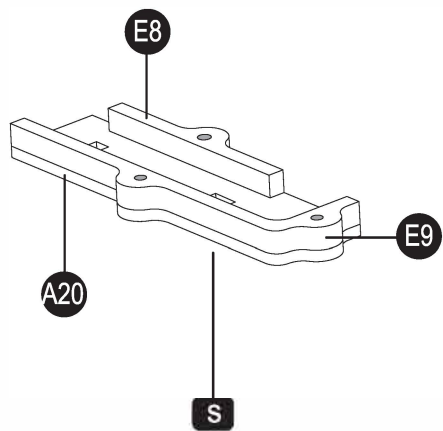
**33**

A28

E24

E25

E26

G5 x4

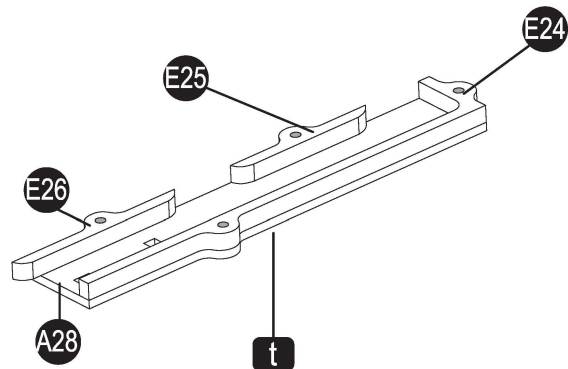
**34**

A21

E20

E21

G5 x4

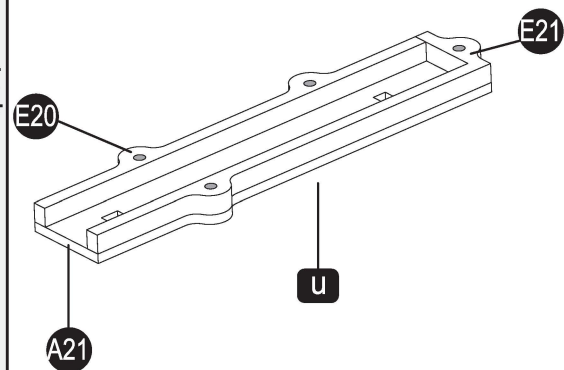
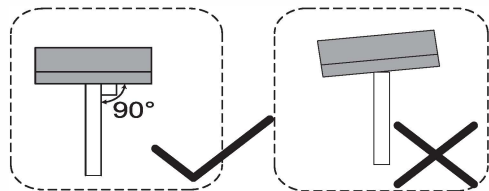
**35**

Zeskanuj kod QR aby
zobaczyć film
instruktażowy.

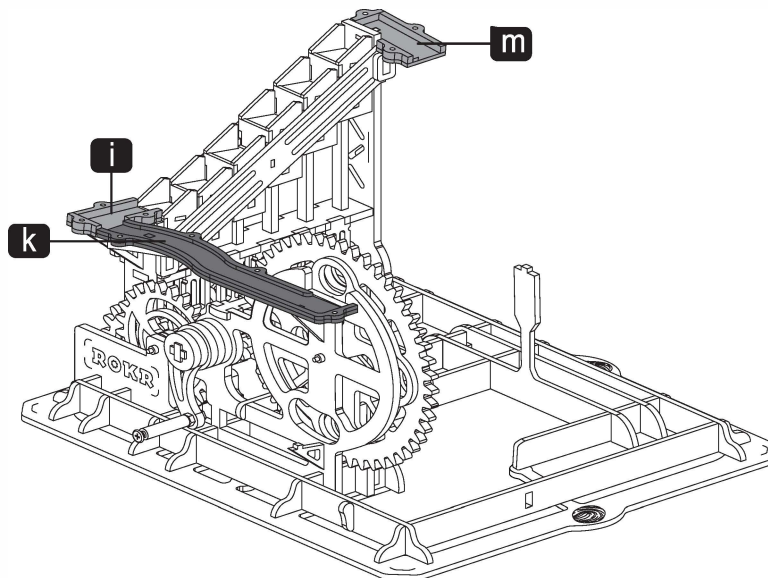

36

B10

B18

B24

B26

B28

B29

B30

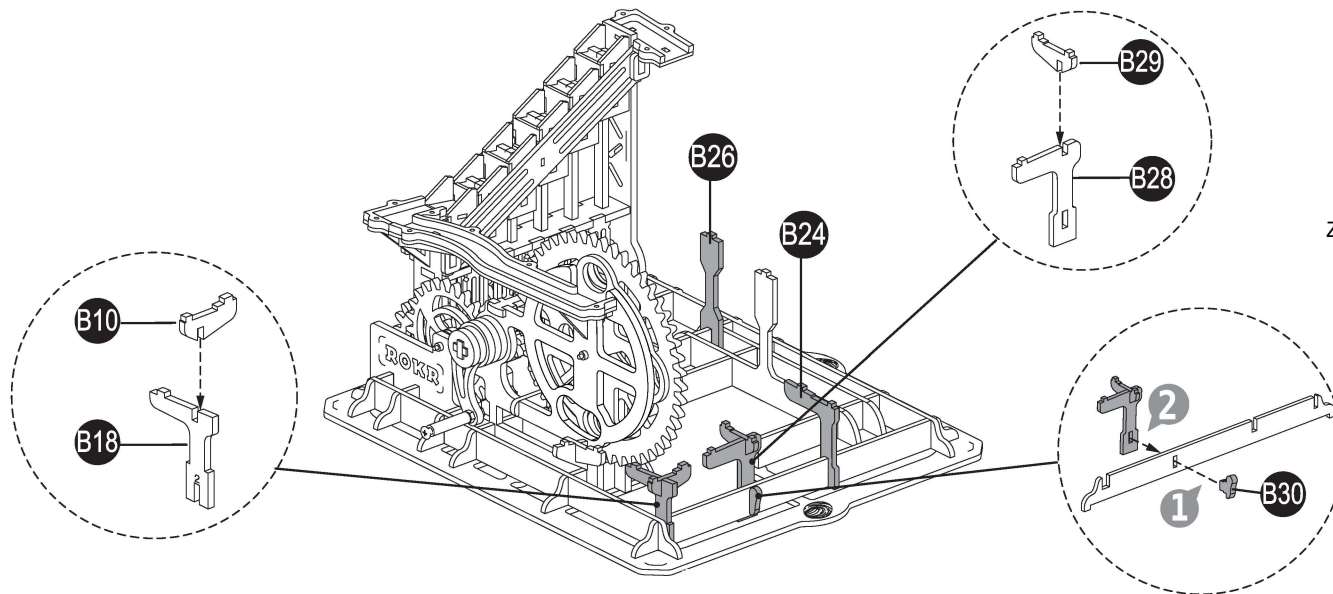

Zeskanuj kod QR aby
zobaczyć film
instruktażowy.

37

B20

B21

B22

B23

B25

B30

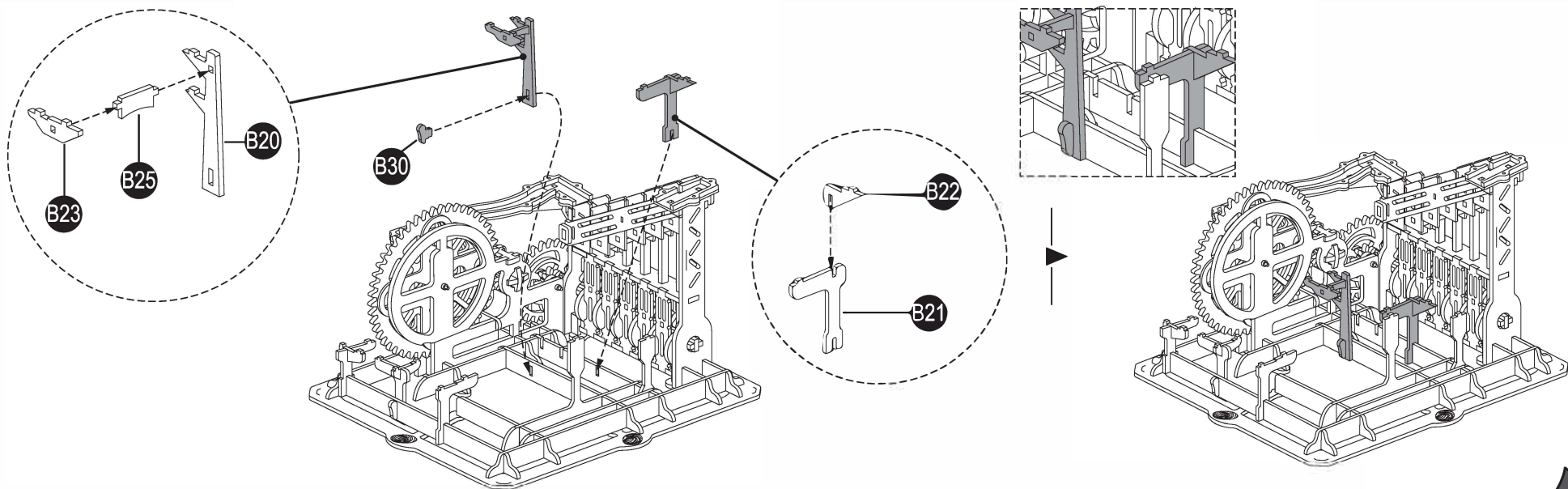

38

A22

A23 x2

A24

D23

G5 x2

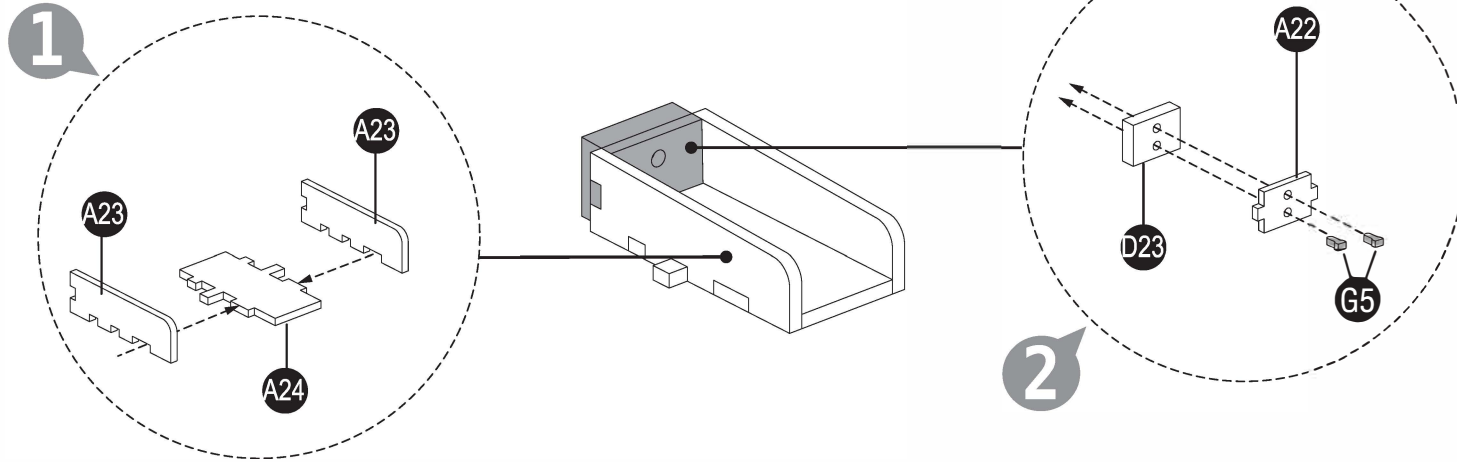

39

A25

B13 x2

C4

D17

D18

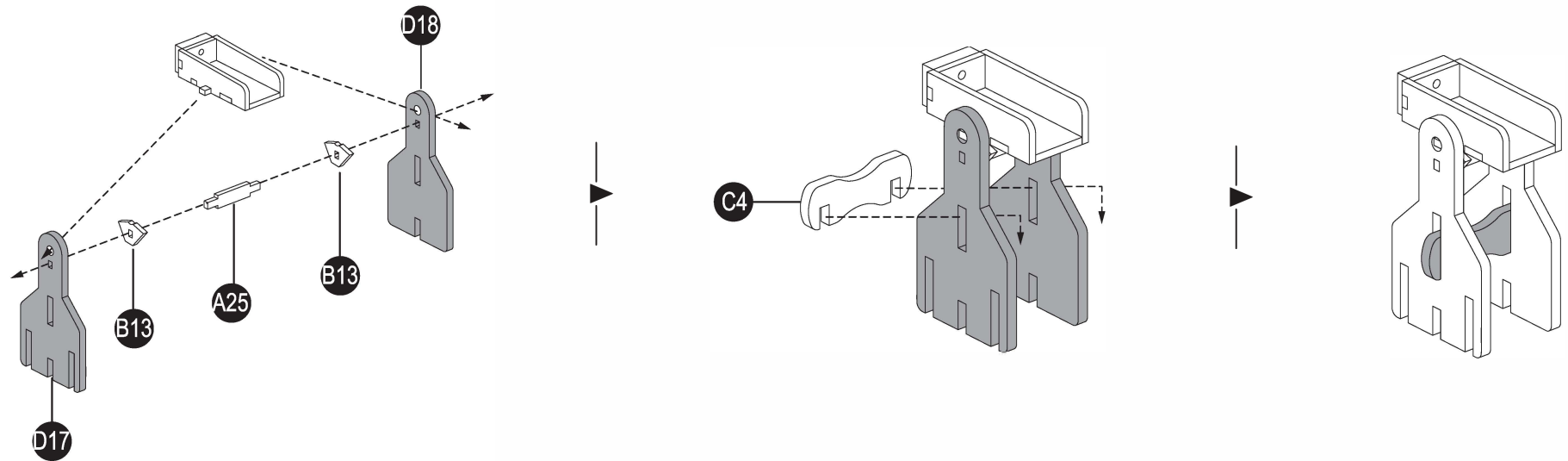

40

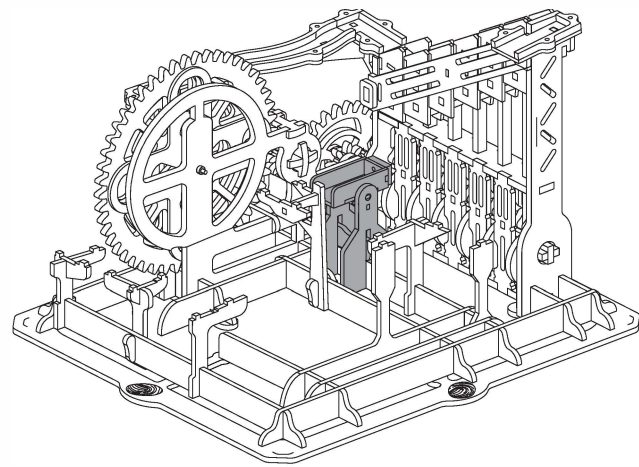

41

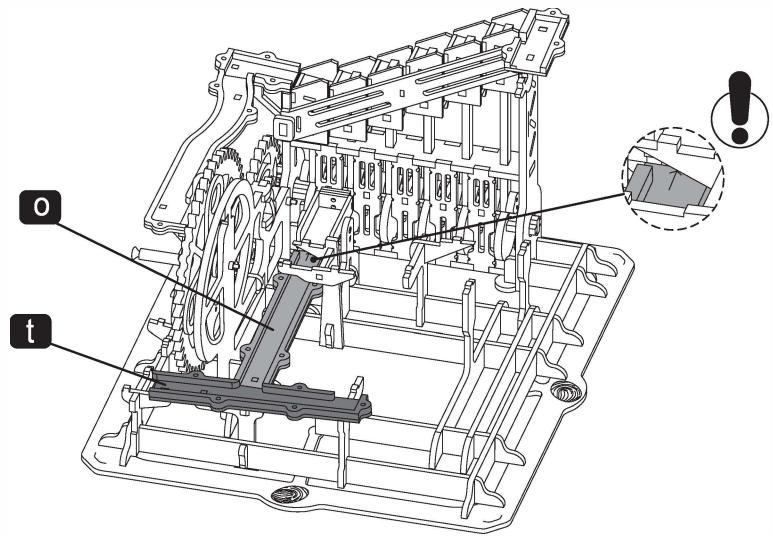

42

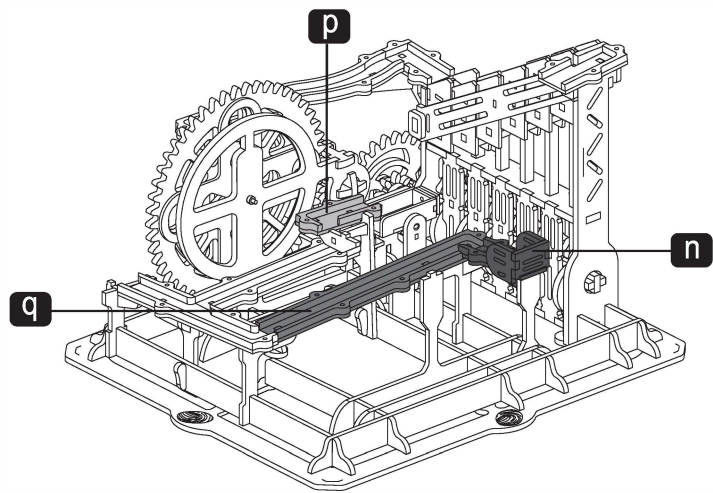

43

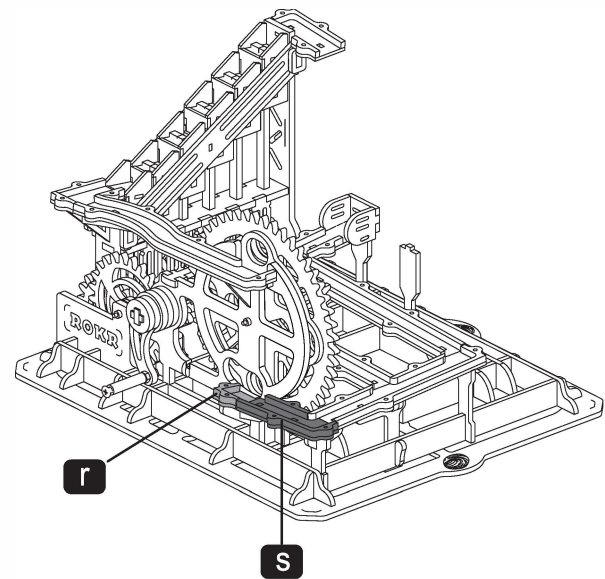

44

A26

A27

G6 x2

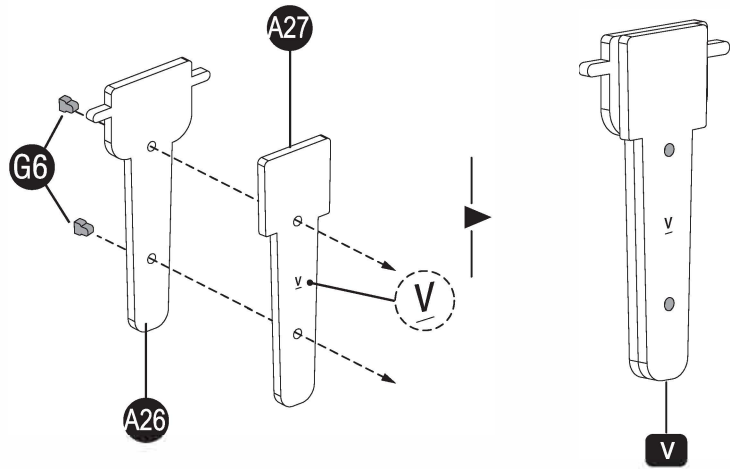
**45**

A32

A33

G6 x2

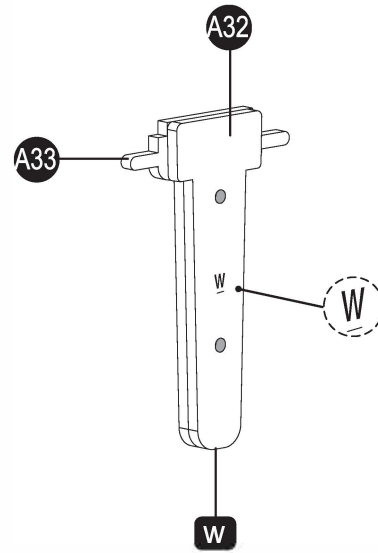
**46**

A19

A18

G6 x2

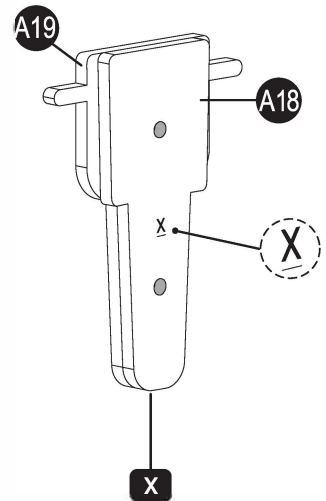
**47**

A30

A31 x2

E28

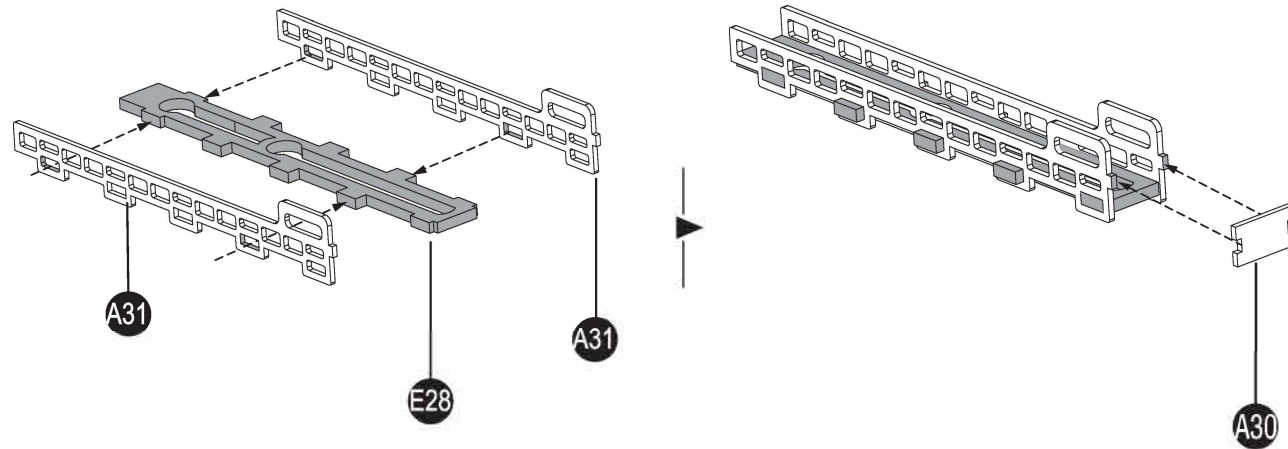
**48**

E29

G1 x2

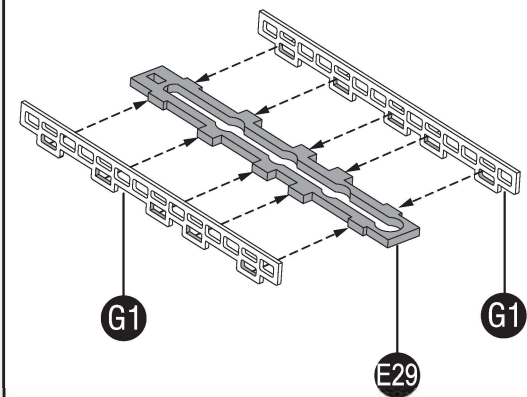

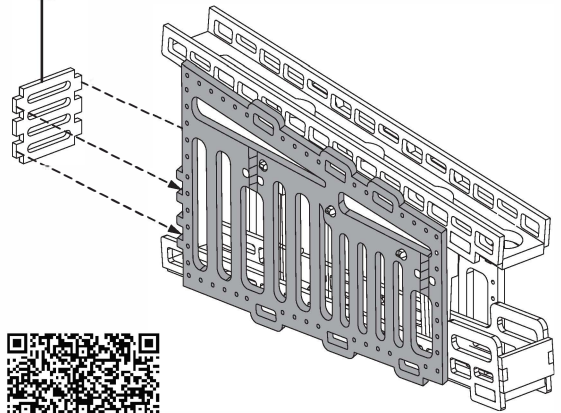
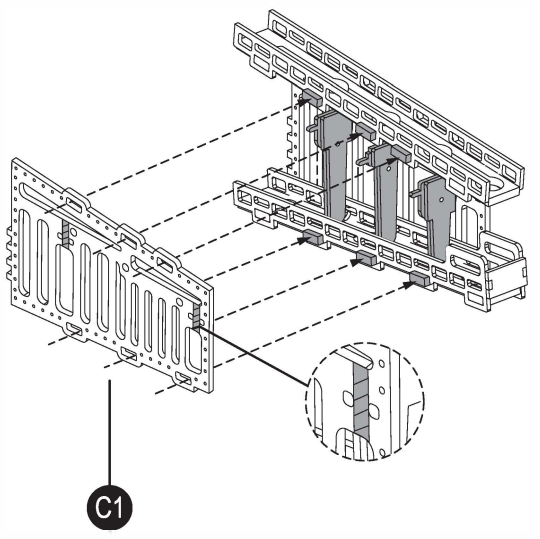
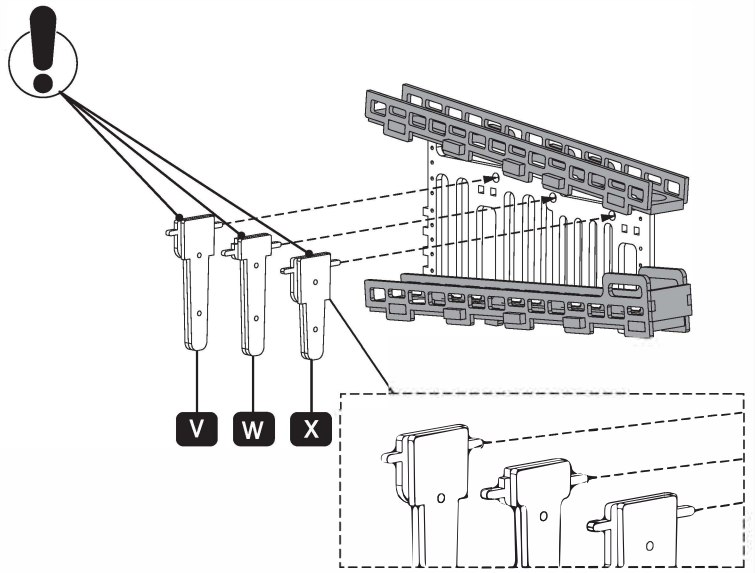
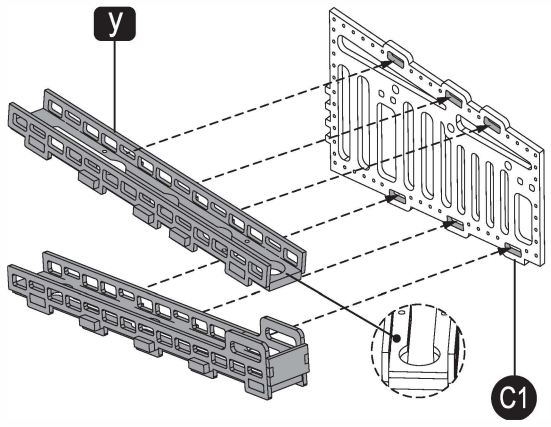
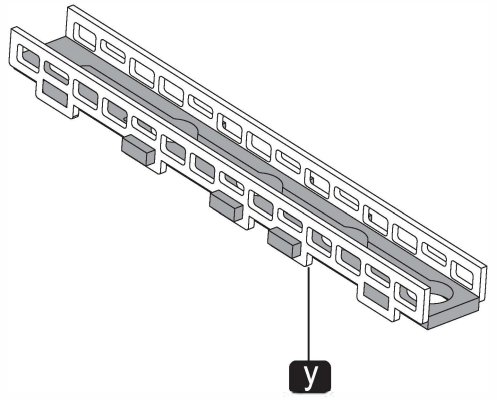

Zeskanuj kod QR aby zobaczyć film instruktażowy.

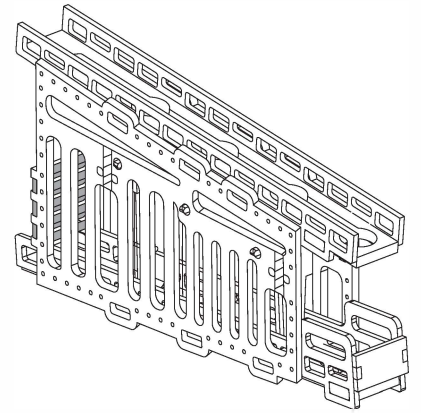

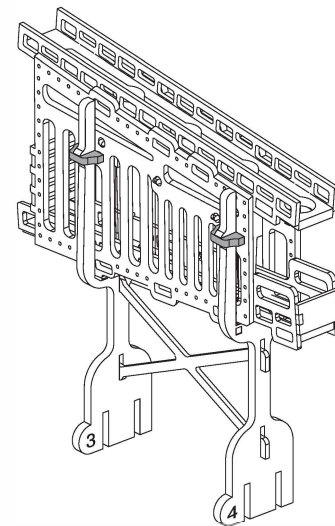
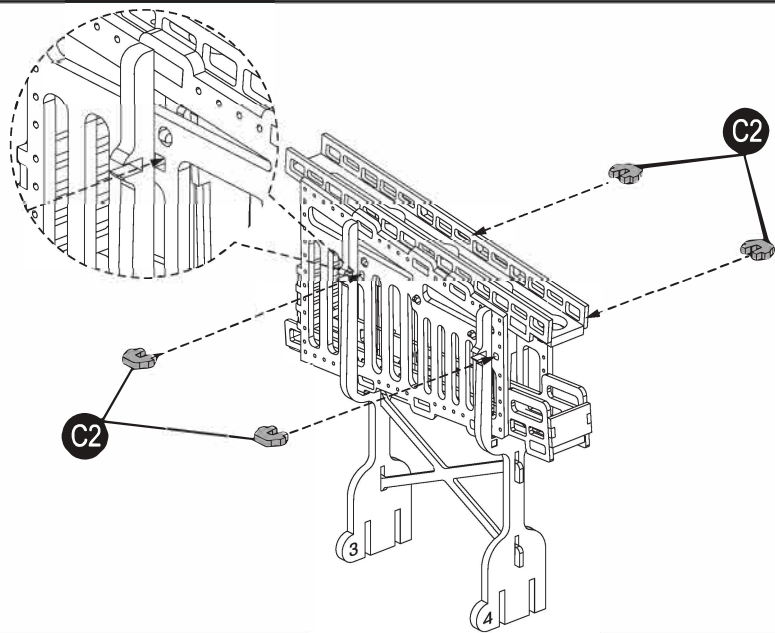
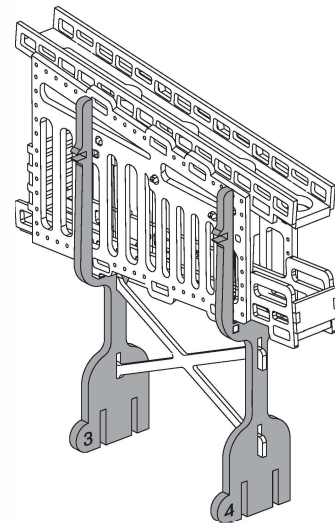
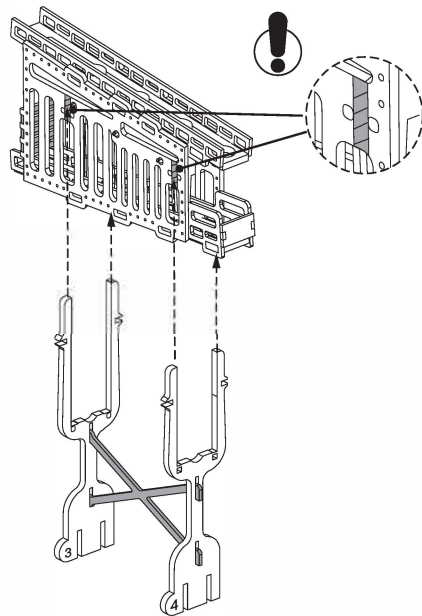
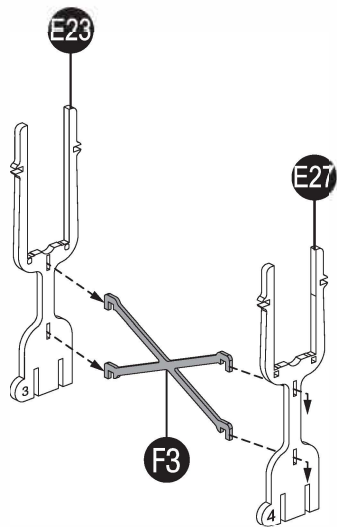

51

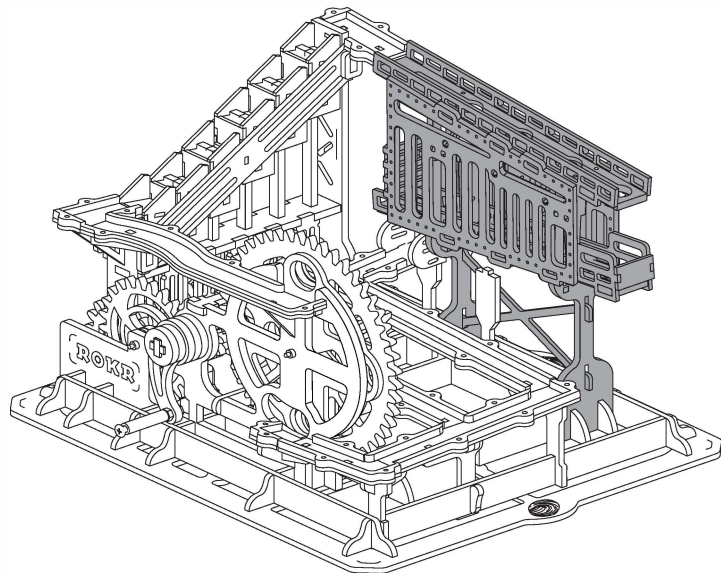
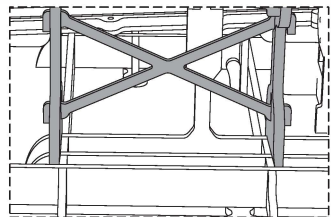

52

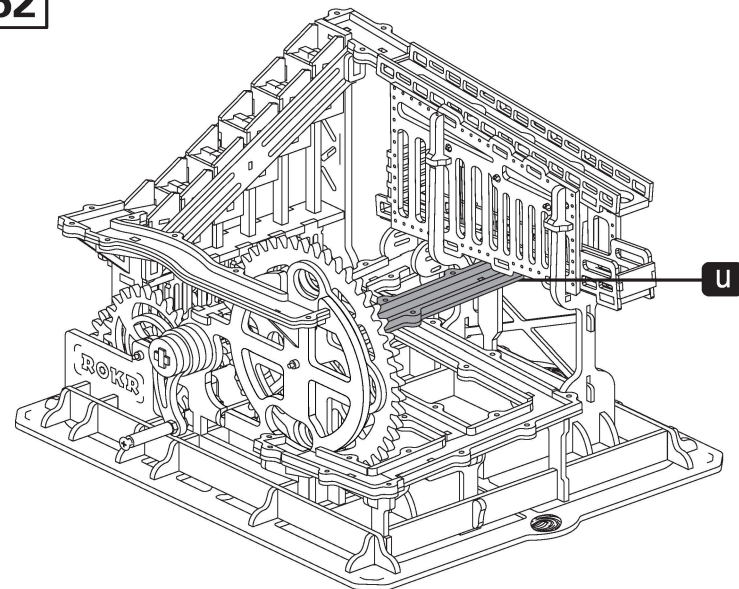

53

B14

B14

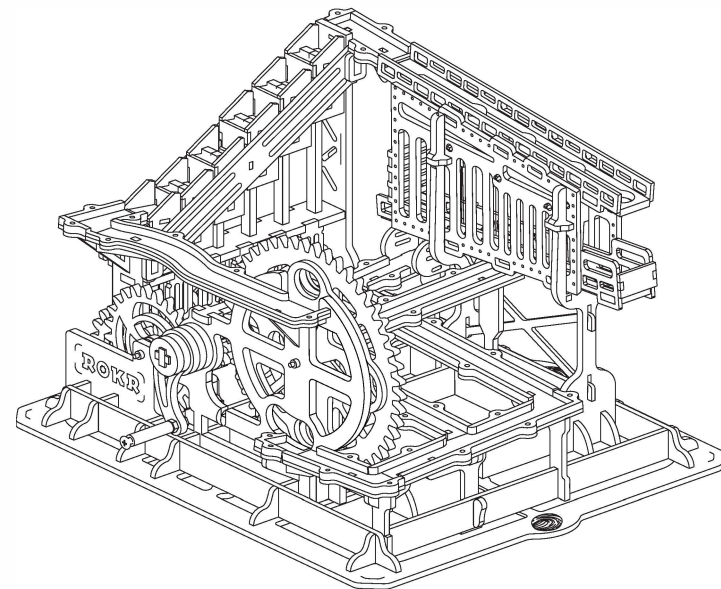
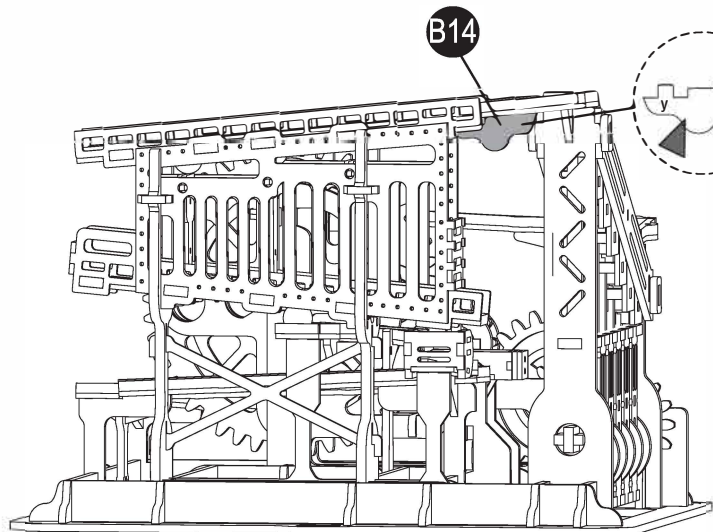
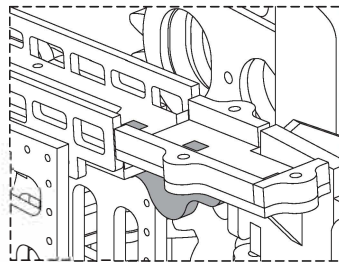
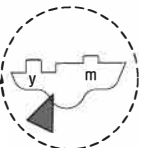

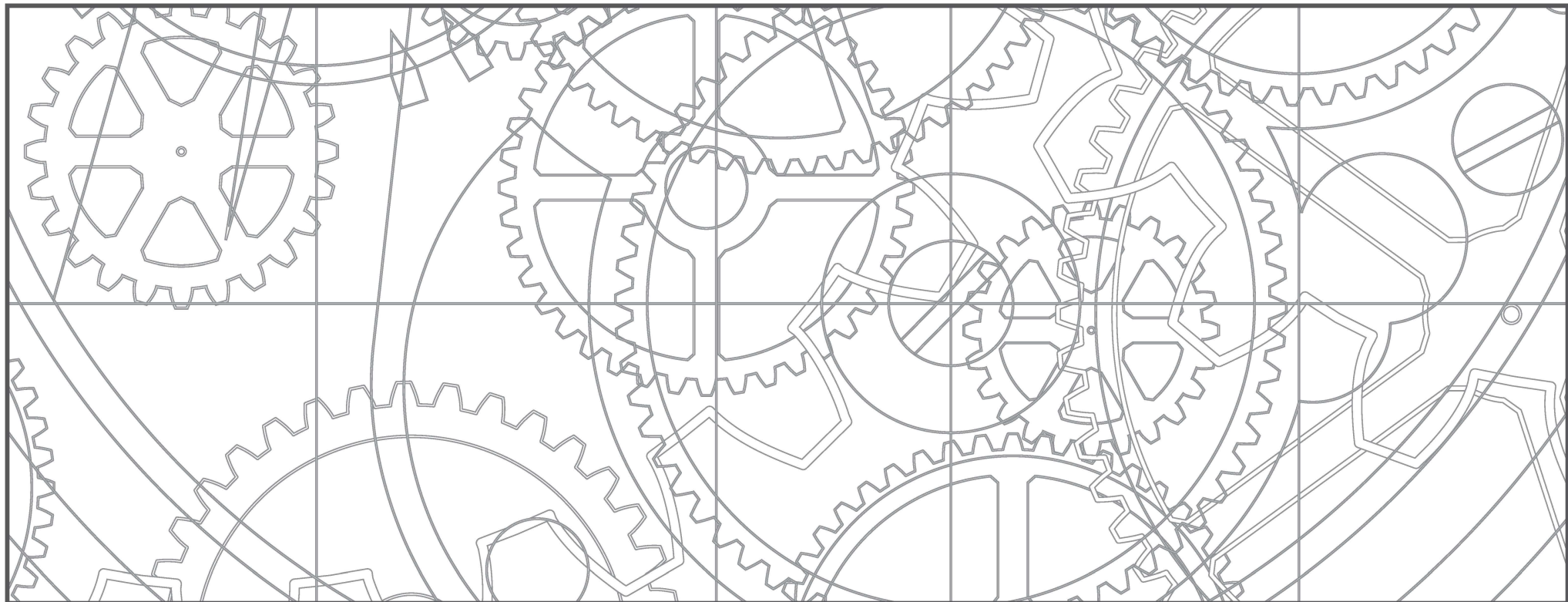

Znajdź nas na
facebook.com/robotimepolska
lub odwiedź
www.robotime.com.pl